

Wireless World

Electronic Calculators

Editor:

H. W. BARNARD

Technical Editor:

T. E. IVALL, M.I.E.R.E.

Deputy Editor:

B. S. CRANK

Assistant Editors:

G. B. SHORTER, B.Sc.

W. E. ANDERTON, B.Sc.

Drawing Office:

L. DARRAH.

Production:

D. R. BRAY

Advertisements:

G. BENTON ROWELL (*Manager*)

Phone 01-261 8339

G. J. STICHBURY

Phone 01-261 8037

A. PETERS (*Classified Advertisements*)

Phone 01-261 8508 or 01-928 4597

Electronic calculators are now being offered in many of the retail chain stores and by mail order companies, although the prices are, apparently, still too high for large scale domestic use. At first sight it would seem that the potential market for small electronic calculators is enormous since almost everybody could use one. It would appear that most of the calculator manufacturers thought the same way, as, according to a report by Creative Strategies Inc., of America, 'nearly every company overestimated the market and severe over production has resulted'. It is true that the market could be very large but only if prices are very much lower than at present. We have heard some large companies on the fringe of the business predict that in about two years time the price for a simple calculator will be below £10, but the experiences of calculator manufacturers do not bear this out.

The first electronic calculators were constructed from a very large number of discrete components; later the industry graduated to using t.t.l. With both of these methods of construction the amount of labour involved was high and this was reflected in the selling price. This gave Japan a large advantage because of her low labour costs, resulting in Japan being dominant in the world's calculator markets. This situation is now changing because nearly all the electronics required for a calculator are available as one integrated circuit. The labour content has thus diminished, and Japan's advantage has been eroded. Now companies from many parts of the world can compete on something like equal terms; in fact many of them use the same basic components!

According to Creative Strategies Inc. the world calculator market is expected to realize peak revenues of over \$500M in 1973 but will slowly decline in spite of increasing production to about \$400M in 1976 due to a continual decrease in selling price. The report also states that Japan's 61% share of the market last year will fall to 26% over the next five years.

There is not much doubt that sales would be enormous in the domestic field if prices could be reduced. We think they will be, in spite of what the manufacturers say at the moment.

How might a low-cost, simple, pocket calculator of the future be constructed? We think it would be built around a complementary m.o.s. chip. The advantages of this technology in this application are obvious: low power supply voltage, single supply rail and very low power consumption. The calculator would be of hybrid construction; the chip and the reflective liquid crystal display (directly driven by the chip) would be laid down on an interconnection pattern on alumina (or cheaper) substrate. The calculator we are visualizing is too small to have a keyboard; instead a metal stylus or pen would be used to touch metallized areas in order to put in information. The metallized areas could even be on the substrate itself. The stylus would be clipped to the side of the calculator and would switch on the calculator automatically when unclipped. The fixed/floating point and 'constant' switches currently used would be replaced with extra logic on the chip, these functions being specified on the 'keyboard'. A calculator built in this way would at the most require four wires to parts not on the substrate, so that production costs would be low.

For some time we have been considering the possibility of an article on calculator construction but have been deterred by the rapid technical progress in this field. We did not want to pursue anything that would be out of date before publication. The industry has now stabilized, for a short time at least, with calculators designed round a single integrated-circuit arithmetic unit. We are therefore very pleased to announce the *Wireless World* desk calculator, designed by Roger Alexander of Advance Electronics, which will be described in two articles starting in the September issue. The calculator uses an m.o.s. chip which carries out all the arithmetic, control and storage functions, reducing construction to a simple task. The calculator chip is connected to four i.cs which drive an eight-digit gallium arsenide display. The clock generator is a hybrid i.c. and the two power supplies are formed by two monolithic i.cs. The 'negative feel' keyboard uses magnet operated reed switches. The calculator functions in the floating point mode with the following features: addition, subtraction, multiplication, division, multiplication or division by a constant, automatic squaring, overflow indication, leading zero suppression, negative number indication, error indication and answer decimal point to 16 places. A kit will be available containing all components, a printed circuit board and an attractive plastics case. The price? Only £39.25.

S.S.B. on Medium Waves?

Can we get more broadcasting channels into the available frequency band?

by G. Wareham

The European medium-wave broadcasting band has been getting into a mess in the years since the Copenhagen Plan of 1948. More than half the present-day transmitters are not authorized by the Plan. Some transmitters use excessively high power, with the result that ionospheric modulation (the "Luxembourg Effect") hampers the reception of other stations in line with them. In addition, there is now a widespread source of local interference in the form of whistles caused by harmonics of line timebase oscillators in television sets.

Voices have been raised from time to time in favour of adopting single-sideband broadcasting as a means of doubling the available channels. Others are inclined to write off the medium waves for broadcasting purposes and concentrate on v.h.f./f.m. with its advantages of freedom from interference and noise, and potential high quality.

What future, if any, has medium-wave broadcasting? The technical problems — overcrowding and excessive powers — are manifest, and the engineer naturally searches for engineering answers. But the problem involves economics and politics as well. So before looking at some specifically technical proposals it may be worth while examining the situation in a more general way.

Need for m.w. broadcasting?

The argument against m.w. broadcasting is straightforward: v.h.f./f.m. is technically better. Yet there are some good reasons for continuing with medium waves:

1. Exclusive m.w. transmissions. So long as people want to listen to programmes which are put out only on medium waves there will be a demand for m.w. receivers. In the U.K., for instance, there is an audience for Radio Luxembourg.

2. Capital wastage. Much money is tied up in m.w. transmitters and receivers. The cost of abandoning m.w. broadcasting must include the writing off of all this capital.

3. National emergency. V.h.f. has limited range. It is conceivable that in a national emergency, such as very widespread flooding, the local v.h.f. transmitters might

be put out of action. The authorities would then need medium waves for broadcasting messages to isolated people.

4. Picnic situation. Near ground level a v.h.f. receiving aerial is not very effective and elsewhere may be in a shadow. This restricts the use of portable v.h.f. sets. "Picnic situation" describes one typical example of such adverse conditions, but it should be remembered that similar considerations may apply to the use of v.h.f. portables in the home and in cars.

These factors are perhaps sufficient in themselves to clinch the case for keeping on domestic broadcasting on medium waves, but there is now an additional, political consideration. This is the widespread use of m.w. for international broadcasting. This use may not have been uppermost in the minds of the Copenhagen planners but a great deal of broadcasting across frontiers does go on, and it would be unrealistic to expect either crusading governments or commercial operators to abandon it. The worst offenders against the Copenhagen Plan fall into these categories.

Strategies for change

For these reasons it seems inevitable that m.w. broadcasting will continue. So it is helpful to take a closer look at the nature of the present problem in Europe.

The key fact is that the range of m.w. transmitters varies greatly between day and night. In daytime, with no ionospheric reflection, reception is purely by ground-wave, with a very limited range. In order to achieve complete ground-wave coverage of a large region by day a number of spaced transmitters may be required. By night, on the other hand, there is ionospheric reflection, and the sky-wave range of a transmitter is perhaps twenty times its daytime ground-wave range.

In theory, therefore, a relatively small number of night-time transmitters could cover a large region such as Europe. But in practice the number of transmitters is not reduced after dark. They all go on working, filling the air with signals which interfere with reception at great distances, especially when they are on the wrong wavelength.

In Europe it is usual to attempt "area

coverage"; i.e., to enable all the residents in an area to receive the programmes put out by the broadcasting authorities in that area. (An alternative policy, practised in the U.S., is to graduate the quality of coverage in accordance with the local density of population, providing the best reception in the most populous localities.) It has been estimated^{1 2} that, on an area-coverage basis, there is enough bandwidth, at present-day legitimate channel spacings, to enable four domestic programmes to be reliably received by ground wave during daylight hours anywhere in Europe. By night, however, the situation changes drastically. The effective area becomes, not some small local region, but a large chunk of Europe. There is room for only one local programme in each area, but nine foreign programmes can now be received in that area. This is a small number in relation to the total number of channels, and explains the cacophony which is to be heard every night in the real Europe, where transmitters are not operated to an optimum plan.

From this analysis various possibilities emerge. We may be pushed towards an American situation, with m.w. broadcasting mainly on a local basis, with severe shrinkage of service areas after dark. Or perhaps m.w. will come to be used for a few international broadcasts, everybody else having given up and gone over entirely to v.h.f. for local stuff. Most likely, however, things will go on much as now, with gradually deteriorating reception.

It is here that the possibility of more channels by using single-sideband transmission and reception becomes relevant. The only positive action possible is to carve up the available bandwidth into enough portions to satisfy the customers, for the time being, but bearing in mind the tendency for transmissions to expand and overfill the available bandwidth. Single-sideband offers the greatest increase in the number of channels, yet to adopt it at once, using the closest possible channel spacing, would be to take a giant stride to a position where, if the situation again deteriorates, no further accommodation is possible.

Broadcasting authorities, being no fools, are well aware of this, and prefer to

approach chaos by small, slow steps. The principle likely to be applied at European Broadcasting Union meetings in the immediate future is: make the smallest changes consistent with avoiding an intolerable state of affairs. It is unlikely that this will involve the adoption of s.s.b. even in the medium term. All the same, the longest journey begins with one small step, so it is prudent to assume that we shall come to s.s.b. in the end, which brings us back to engineering. Engineers have been investigating the problems and possibilities, some of which are described below.

Transmission systems

A number of possible modulation systems exist. Each has its advantages and disadvantages.

Pure s.s.b. This is the most efficient system from the transmission point of view. It uses the minimum bandwidth and there is no "wasted" carrier power. The problems lie at the receiver. Envelope detection (e.g. ordinary diode detection) cannot be used. This makes pure s.s.b. incompatible with existing a.m. (i.e., double-sideband plus carrier) receivers. The pure s.s.b. receiver must contain an oscillator (more than one in a superhet) stable to within a few hertz of the incoming signal's "missing" carrier, since the audio is recovered by "carrier reinsertion". This process amounts to beating all the incoming sideband frequencies with a local carrier nominally identical in frequency with the original one. Any frequency error destroys the harmonic relationships of a complex audio signal. Thus, if the error is 10Hz, original audio frequencies of 300 and 600Hz are detected as 310 and 610Hz, which are no longer harmonically related. For natural quality the error should be less than 5Hz. This implies a local oscillator stability to within 5 parts per million at 1MHz. Only a good crystal oscillator can provide this.

S.S.B. + C. If the full carrier and one sideband are transmitted, an envelope detector can be used. The price, at the transmitter, is "wasted" carrier power, and at the receiver whistles from adjacent carriers, and harmonic distortion. The distortion reaches a theoretical 23% at 100% modulation but is much reduced at normal modulation depths, where it becomes comparable with the distortion of practical diode detectors with a.m. signals.

If only a reduced carrier is transmitted an envelope detector cannot be used, but exalted-carrier or synchrodyne detection is still possible.

C.S.S.B. Various systems of "compatible single sideband" modulation are known^{3,4}. They are essentially amplitude-modulation systems in which the carrier is not constant in frequency but is phase-modulated by the audio signal in such a way that the sideband power lies to one side of the nominal carrier frequency instead of both sides as in a.m. The result is a spectrum which is superficially like an a.m. spectrum, but with what looks like an ordinary a.m. envelope. An envelope detector can therefore be used.

In practical systems harmonic distortion is incurred. This is because the bandwidth needed for distortionless reception is greater than the bandwidth of an equivalent s.s.b. transmission. When the c.s.s.b. bandwidth is filtered down to a comparable amount, the detector produces a distorted output. In practice the distortion is not severe in comparison to what listeners habitually put up with in existing a.m. receivers.

The c.s.s.b. systems require extra circuitry at the transmitter (Fig. 1) and if maladjusted may cause out-of-channel emission. While compatible with normal amplitude modulation, c.s.s.b. is not compatible with pure s.s.b., since there is no constant carrier to reinsert in c.s.s.b. A further problem is that although the c.s.s.b. spectrum may be constrained to occupy the same bandwidth as an s.s.b. signal the distribution of energy in the two spectra is different. In c.s.s.b. there is more energy at frequencies farther from the nominal carrier. This means that adjacent-channel interference may be worse with c.s.s.b.

Vestigial sideband a.m. Most of the distortion which occurs when an s.s.b. + c. signal is envelope-detected involves the lower modulation frequencies, since these are strongest in most programme material. If the part of the "unwanted" sideband closest to the carrier is transmitted, the lower-frequency modulation is received as ordinary a.m. and detector distortion is reduced. "Vestigial sideband" also eases reception by exalted carrier and synchrodyne techniques. Disadvantages are the greater transmission bandwidth and transmitter complexity.

Common-base frequency allocation. Many of the problems of receiver tuning would disappear if all carrier frequencies were multiples of some common "base frequency". Thus, in a system with 5kHz channel separation, all carriers would be multiples of 5kHz.

If a stable 5kHz signal were then available at the receiver the local oscillations required for frequency-

changing and demodulation could be derived from the 5kHz by frequency multiplication. The whistles found in superhets would also be reduced, since many would occur at 5kHz or its multiples and be easy to reject with a fixed filter.

The receiver tuning may be discontinuous, moving in 5kHz jumps, each step coinciding with a broadcast channel. Mistuning would then be impossible (except by tuning to the wrong channel altogether). Some receivers for base-frequency systems are described below. They rely on obtaining the base frequency from some separate source such as a crystal oscillator. However, there seems no reason in principle why the base frequency should not be transmitted as a pilot tone. Since it would coincide with the carrier in the adjacent channel no new whistle problems would be created.

If the base frequency were not 5kHz but an exact submultiple of the local television line frequency all timebase harmonics would coincide with the carriers of m.w. stations and would be inaudible or give rise to fixed-frequency whistles identical with inter-carrier whistles and easily filterable.

A further possibility is to derive the base frequency from the local television signal, by means of an auxiliary receiver as suggested by Netzband (see below).

Reception systems

It is universally recognized that the feasibility of s.s.b. broadcasting will depend on keeping down the cost of the receiver. Techniques which are perfectly acceptable in a communications receiver may be too expensive to be transferred to the domestic market, where the yardstick of cost is the price of a present-day "pocket portable". People will not pay much for marginally better performance, as is shown by the slow progress of v.h.f. receiver sales in the U.K.

Certain requirements are common to various types of s.s.b. system, and these will be considered before particular receiving systems.

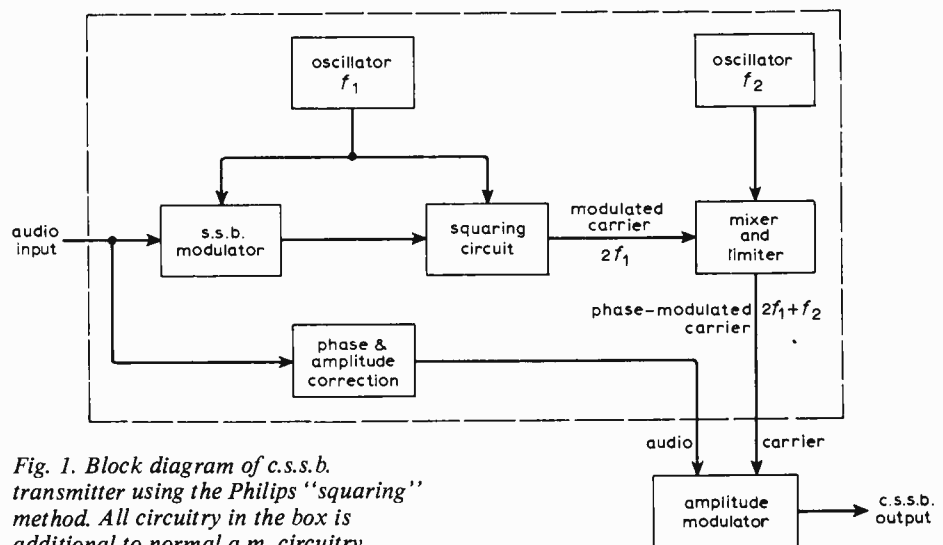

Fig. 1. Block diagram of c.s.s.b. transmitter using the Philips "squaring" method. All circuitry in the box is additional to normal a.m. circuitry.

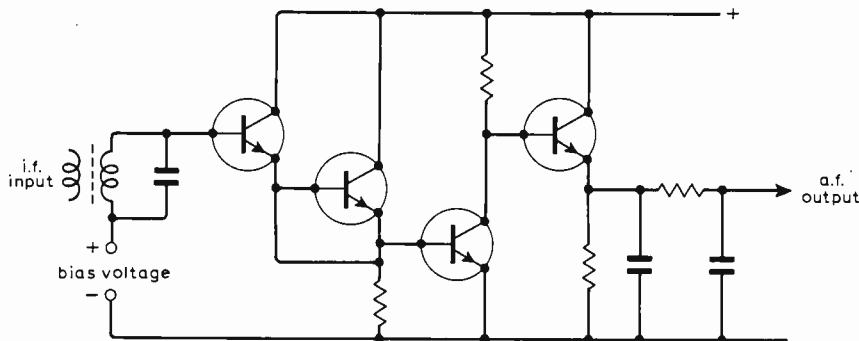

Fig. 2. Low distortion detector (used in TAD100 integrated circuit).

I.F. filtering and whistle suppression

Closer channel spacing implies the use of sharper i.f. filters. It is unlikely that, in the confines of a pocket portable, adequate filtering can be obtained from LC circuits. The alternatives are quartz-crystal filters, mechanical filters, and ceramic-resonator filters. Quartz filters are too expensive; mechanical filters are vulnerable to shock; so ceramic resonators seem the best bet. If closer channel spacing and transmitted carrier are adopted some form of intercarrier whistle filter becomes desirable. A possible solution is an *m*-derived active filter with its rejection slot at the whistle frequency. The active part of the circuitry is already in existence in i.c. form and the frequency-determining components could perhaps be cheap carbon-film resistors and polystyrene capacitors.

Receivers for s.s.b. + c.

A conventional superhet may be used for s.s.b. + c., provided that its i.f. response is narrow enough. Local oscillator drift may then be a problem if the channel spacing is small. At 5kHz spacing, for example, the permissible mistuning error is about 1kHz. This is already greater than the initial tuning error to be expected when unskilled users operate the receiver, so there is no margin for oscillator drift. An associated problem is that most receivers are not equipped with a fine enough tuning control.

If it can be assumed that an unskilled operator can be enabled to reduce the initial tuning error to nearly zero — for example by fine-tuning until an inter-carrier whistle disappears — then a permissible drift of 1kHz requires a local oscillator stability of around 1 part in 1000. This must be maintained for a reasonable listening period (say one hour) and in the face of a fading battery voltage and the temperature changes to which portable receivers are subject. Quite a formidable problem for the designer.

A second requirement for s.s.b. + c. is reduced distortion in the detector and audio stages. As mentioned above, there is an inevitable distortion of 23% at 100% modulation, even with a perfect detector. Ordinary diode detectors are very far from perfect, and the inevitable class B amplifier which follows them does not make matters any better. Some improvements to these

parts of a receiver are therefore desirable, and fortunately the means are already to hand. The use of integrated circuits in a.m. receivers has led to the development of a transistor analogue of the old "infinite impedance detector" (Fig. 2). This does not have the unfavourable a.c./d.c. load ratio of the ordinary diode and distortion is much reduced. Similarly there is no reason, apart from a relatively small increase in cost, why low-distortion integrated amplifiers should not be used.

Reinforced carrier

If the level of the s.s.b. + c. carrier could be increased relative to the sideband level distortion could be reduced. The classical solution, exalted carrier reception (Fig. 3(a)), achieves this by means of a very sharp carrier-extraction filter. While a sharp enough filter can be made, using a quartz resonator, it leaves the receiver wide open to the effects of mistuning and local oscillator drift. Exalted carrier reception is only useful, therefore, when backed up with some form of frequency-stabilization.

An alternative is the synchrodyne detector (Fig. 3(b)). Here the carrier is used to lock an oscillator, whose high-amplitude output is applied to a switching-type demodulator with low distortion. The sidebands are largely suppressed by the oscillator, which also

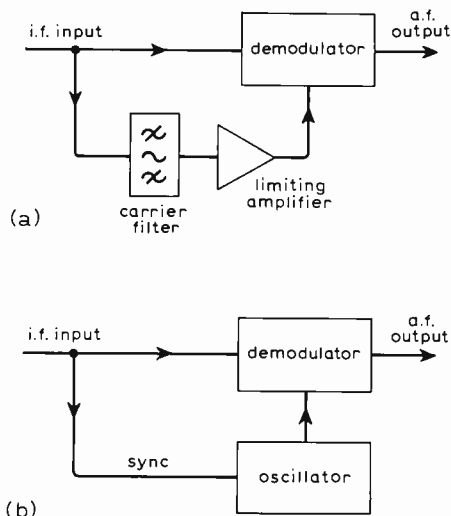

Fig. 3.(a) Exalted carrier detector; (b) synchrodyne detector.

gives an effective gain, since the sync level need be only about 20% of the oscillation amplitude at the point of injection. The effective bandwidth of a synchronized oscillator can be made arbitrarily small, but this is of no interest in the present case because of the danger of first oscillator drift and because it gives rise to a loud tuning-in whistle. However, it is also possible to make the locking bandwidth quite large. If it is larger than the i.f. bandwidth, then to a first approximation the tuning is flat and the oscillator locks to the strongest signal in the i.f. passband, which is the carrier.

In this way the 'problem of local oscillator drift is circumvented. But there are other difficulties. The system is vulnerable to selective fading. If the carrier fades relative to the sidebands then the oscillator may lock temporarily to the sidebands, giving bad distortion. There may also be difficulties with a.g.c. The d.c. output of practical balanced demodulators (which is proportional to the carrier) is rather small, so an amplified a.g.c. system may be needed. In addition, the d.c. output varies with the relative phase of incoming carrier to local oscillation, falling to zero when this reaches 90 degrees.

Phase-locked receiver

As noted above, the exalted-carrier technique fails, in the simplest form, because local oscillator drift takes the carrier outside the passband of the sharp i.f. carrier filter. This problem can be dealt with by adding a frequency correction system to keep local oscillator drift within limits. An attractive (and "integratable") way of arranging this makes use of a phase-sensitive detector operating at the i.f. One such system was embodied in a receiver developed at Philips Research Laboratories⁵ and shown in Fig. 4.

The phase-sensitive detector receives two signals — a pure, constant-amplitude filtered and limited carrier and the raw i.f. signal which contains the carrier and sideband. The raw signal is given a 90-degree phase shift by a network assumed to be insensitive to frequency changes. The filtered carrier has nominal zero phase shift, but the phase-frequency characteristic of the carrier filter is such that the phase departs rapidly from zero as the frequency goes off-centre, changing positively in one direction of frequency shift and negatively in the other. The effect of such deviations is to give corresponding positive or negative d.c. outputs from the phase detector, and these, after smoothing to remove modulation, are applied as a.f.c. to the first oscillator.

The designers say that, in a practical receiver, the catching range of the phase-lock system was 2kHz and the holding range 4kHz. The carrier was found and held even when noise was great. Tuning was said to be "even easier than with normal a.m. receivers".

This is encouraging, but it is worth pointing out that phase-locked receivers do have a drawback. If the carrier fades selectively, the system may lock to the sideband, or even to an adjacent carrier.

These disturbances to reception may last for an appreciable time, since the effective bandwidth is very small, being a function of the low-pass filter, which has a cut-off frequency of perhaps 2Hz. Immunity to the worst effects of selective fading (harmonic distortion) is often claimed for s.s.b., but it can only be fully realized in a receiver with its own built-in stable frequency source.

Pure s.s.b. receivers

The simplest method of detecting an s.s.b. signal is to beat it against a local oscillation whose frequency corresponds to the missing carrier. Unfortunately this method is capable of detecting either sideband, so any signals in the unwanted sideband appear as noise and interference. The system is wide open to interference from one of the adjacent channels.

To overcome this, a system has been devised (Fig. 5) in which signals from the unwanted sideband are phased out after detection. Detected signals from the unwanted sideband which emerge from the 'I' and 'Q' (in-phase and quadrature) paths reinforce one another when added, but those due to the unwanted sideband cancel. If the transmission in the two paths is the same (equal gains), and the phase shifts are exactly 90 degrees, cancellation is perfect. In theory no r.f. selectivity is required since signals from all other channels emerge as higher frequencies than the wanted audio band and can be rejected by a low pass filter in the audio circuit. In practice, the demodulator responds to harmonics of the local oscillator so some r.f. tuning is required.

Apart from the stability of the local oscillator, the main problem is the design of the 90° audio phase shifter. This must give a constant phase shift over several octaves. It must also have a flat frequency response. These requirements cannot be met, and practical direct conversion receivers make use of differential audio phasing networks which give a 45° advance in one leg and a 45° lag in the other. Even so, suppression of unwanted signals may only be around 30dB.

Maintenance of the required 90° shift at the oscillator frequency over a whole tuning band may be difficult. The problem can be solved neatly, at a price by the automatic quadrature circuit in Fig. 6.

Superhet for pure s.s.b.

This consists of a conventional front end followed by a narrow i.f. filter, accepting one sideband only, and finally a "product detector" (switching demodulator) driven by a b.f.o. or carrier reinsertion oscillator operating on the skirt of the i.f. passband. Although manually tuned superhets are used by amateurs they are hardly a practical proposition for domestic s.s.b. reception. Even if the local oscillator could be made stable enough, far too much skill is required when tuning in.

The only hope for pure s.s.b. broadcasting, therefore, is to provide a stable frequency synthesizer giving just the right frequencies, so that mistuning is impossible. Crystal oscillators of the

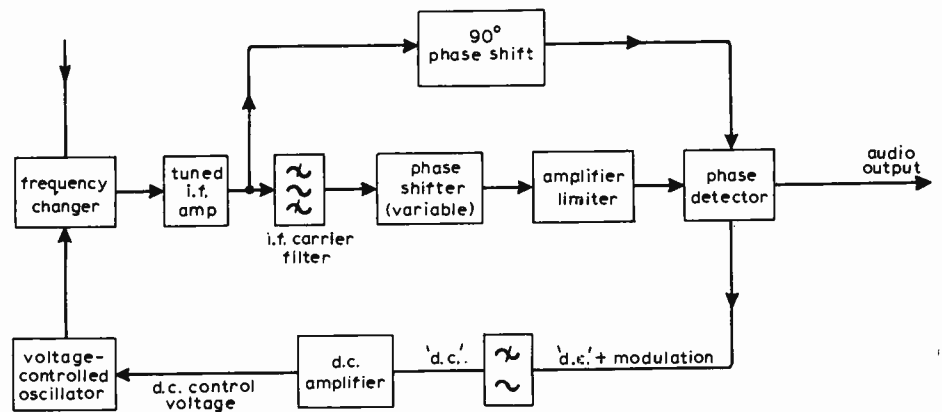

Fig. 4. Phase locked s.s.b. + c. receiver.

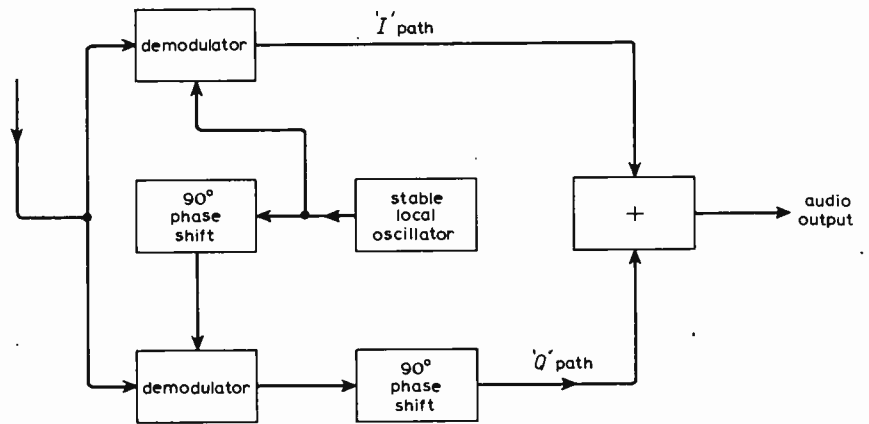

Fig. 5. Direct-conversion s.s.b. receiver.

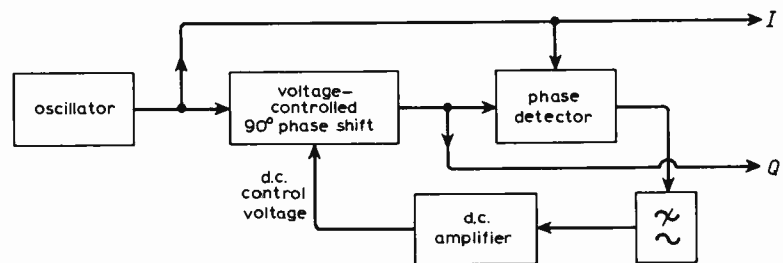

Fig. 6. Automatic quadrature phase splitter.

required stability exist, and so do the necessary dividers and multipliers in i.c. form, but they are too expensive for domestic use.

One technique which shows promise is the use of PAL delay lines to force a local oscillator to operate only on discrete frequencies, corresponding to the wanted carrier frequencies. The technique has been described recently in *Wireless World* (May 1972, p. 218) so will only be briefly outlined here. It makes use of the fact that the phase shift through a PAL delay line is exactly proportional to frequency and changes by 180° for every change of 15,625Hz (i.e., the line frequency). With the help of a phase detector this property can be used to provide a sort of "staircase" of discrete frequency-control voltages for a voltage-controlled oscillator. Each step in the staircase corresponds to a stable locking point, separated from its neighbours by 15,625Hz. Manipulating the v.c.o. tuning causes the frequency to change in 15,625Hz jumps.

Increments other than 15,625Hz can be arranged by multiplying or dividing the frequency at some point. The PAL delay line operates at 3-6MHz. A v.c.o. on 1-2MHz, multiplied by three before phase comparison, would give steps of 5,208.3Hz, which is a suitable channel spacing for s.s.b. broadcasting. Interference from TV line frequency harmonics would be eliminated by allocating broadcast carriers on a system with a base frequency which is a submultiple of the local TV line frequency.

Receivers for base-frequency channels

Netzband's base-frequency receiver. This interesting proposal⁷ is for a pure s.s.b. receiver. The circuit (Fig. 7) has a conventional superhet front end and suitably selective i.f. stages. But the output of the i.f. section is passed to a second frequency-changer driven by the first oscillator. This transposes the i.f. signals back to their original radio frequencies. The object is to cancel the effects of first

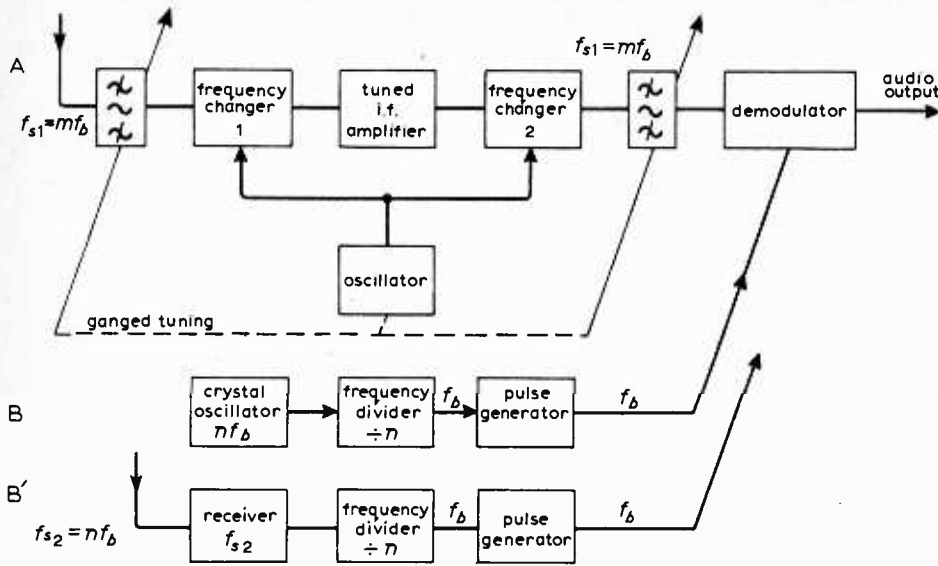

Fig. 7. Netzband's base-frequency receiver.

oscillator drift. What emerges from the second frequency changer (after simple filtering) is therefore the original signal, now freed from all other signals. This isolated wanted signal is now demodulated by a multi-frequency demodulator capable of detecting any signal whose carrier is a multiple of the base frequency. The demodulator is driven by $0.3\mu s$ pulses repeated at the base frequency. Its output contains only the wanted audio plus some low-amplitude beats at the base frequency which are rejected by a low-pass audio filter.

Netzband proposes two methods of generating the base frequency. One, shown as chain B, uses a crystal oscillator and frequency divider. The other (chain B') has an auxiliary receiver tuned to a "standard frequency transmission".

Eden's independent sideband receiver. This is a proposal¹ for transmissions with carrier and two independent sidebands, but is readily modified for s.s.b. + c. The receiver (Fig. 8) is a double conversion superhet with a synchronous demodulator. Frequency stabilization is applied to the carrier reinsertion oscillator which drives

the demodulator. From this oscillator are derived, by means of a simple frequency synthesizer, the two frequencies required by the second frequency-changer. One selects the upper sideband and one the lower.

The first oscillator is synchronized by direct injection of base-frequency pulses, which, in turn, are derived by frequency division of the carrier-reinsertion frequency. In this way all required frequencies are derived from one stabilized oscillator.

The final circuits constitute a direct-conversion receiver operating at the final i.f. Its purpose is to provide additional discrimination against the unwanted sideband, which cannot be entirely eliminated by a practical i.f. filter.

The proposal to synchronize the first oscillator by injecting narrow pulses at the base frequency is unusual and raises the question whether the waveform of the local oscillator will not contain unwanted harmonics of f_b which will beat with unwanted signals and bring them within the i.f. passband. In a study of synchronized oscillators van Slooten⁸ says that a pulsed synchronizing range of

2-3% is obtainable without serious distortion. This is more than enough for the present purpose.

Hardware

Most of the elements required for making an s.s.b. broadcast receiver already exist, though not necessarily in the best form, or at the right price. Notes on a few of the more interesting ones are given below.

Crystal oscillators. Packaged r.f. oscillators of good frequency stability (1 in 10^6) and small size are in use in professional communications receivers. A recent development, which has the merit of being aimed at a mass market for a portable use, is the crystal controlled electric wrist-watch. This will use a lowish-frequency crystal which might be adaptable to base-frequency generation.

The Motorola 32NT crystal oscillates at 32,768Hz (which gives 0.5Hz when divided by 16 bistables). The aging characteristic is given as 5 p.p.m. per year, the temperature drift has a turnover point at 28°C and gives a change of ± 15 p.p.m. for a temperature change of $\pm 5^\circ C$. Resistance to shock and vibration is said to be good. The frequency can be "pulled" over a range of about 100Hz by means of a small trimming capacitance. Suitable m.o.s. frequency dividers have been designed, and their power consumption is very low. All elements are small. (A picture in "New Products" of this issue shows the crystal and a divider i.e. beside a watch case.)

Ceramic resonators. Selectivity is crucial to s.s.b. broadcasting. In a recent study², Eden has shown that the expected increases in coverage from use of closer channel spacings cannot be realized in practice with the usual amounts of selectivity. Increase in adjacent channel interference breaking through the tuning circuits more than wipes out the advantage of the increased number of channels.

The cheapest forms of sharp i.f. filter at present available use ceramic resonators. These are mass-produced elements with the same equivalent circuit as a quartz

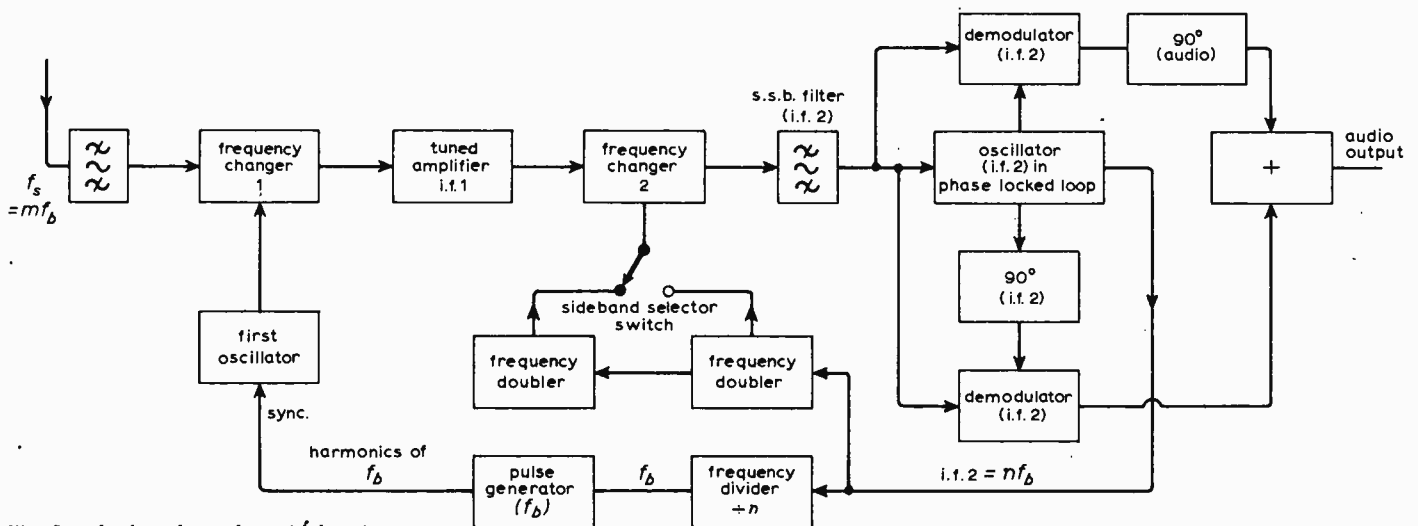

Fig. 8. Eden's independent sideband receiver.

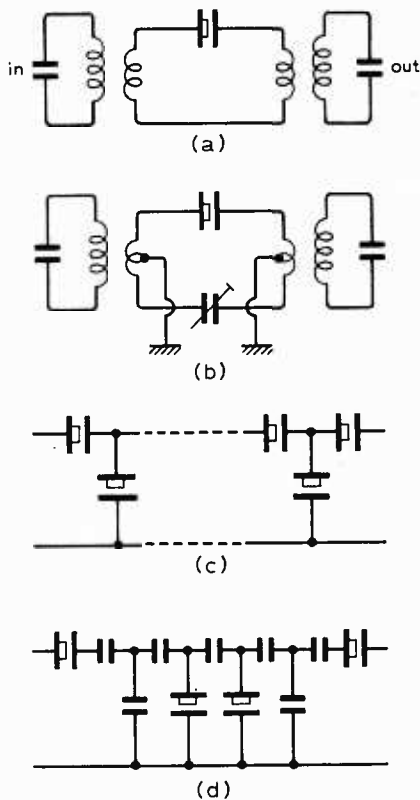

Fig. 9. Ceramic-resonator i.f. filters.

resonator but with different element values (lower inductance, higher capacitances). They are already in use in domestic receivers as the coupling elements between LC tuned circuits (Fig. 9). Circuit (a) gives an asymmetrical response and (b) a symmetrical one. Much better response shapes can be obtained by using a number of resonators. In communications receivers the usual form is the ladder filter (c). This can be made to give a good performance in a small space. As an example, the Vernitron TL-4D8A has 17 resonators, a centre frequency of 455kHz, 6dB bandwidth 4kHz, is - 60dB at not more than ± 4 kHz, and measures about 1½in by 0.3in diameter. Unfortunately it is expensive (over £15 retail). One reason for the cost is that these filters are made from carefully selected and matched elements. An alternative approach (Fig. 9(d)) uses resonators which are nominally identical, and sets the response by adding networks of fixed capacitors to modify the natural resonances. Ordinary 5% tolerance polystyrene capacitors in standard E12 values can be used, and a kit of parts for the filter illustrated can be bought for about £2 retail. The response shape with presently-available resonators is not ideal, nevertheless the filter is a great improvement on LC circuits and many are in use by amateurs for s.s.b. reception.

Integrated circuits. All the circuitry for an s.s.b. receiver is already available, at a price, in integrated form. The Plessey SL600 series of i.cs was indeed designed for the job (apart from frequency synthesis, which can be done using computer type i.cs). The SL621C is a good example. Its purpose is to derive an

a.g.c. control signal from the audio output of a pure s.s.b. receiver. This entails "remembering" the peak audio output, ignoring noise pulses, and compensating for slow (20dB/sec) fading.

Integrated forms of phase-locked loop are at an advanced stage of development (e.g., Signetics NE561B, etc.). The usual format is a voltage-tuned relaxation oscillator whose phase is compared with that of an external reference signal (e.g., the carrier in an s.s.b. + c. signal) and a d.c. control voltage derived to lock the v.c.o. to the reference frequency. In this way a noise-free high amplitude carrier for reinsertion can be derived. The elements of such a phase-locked loop are shown in Fig. 10. In effect, the phase detector samples the reference wave as this passes through zero. The detector output is then zero. Any incipient frequency error causes the sample to be advanced or delayed, giving a d.c. output whose polarity depends on the sense of the phase error.

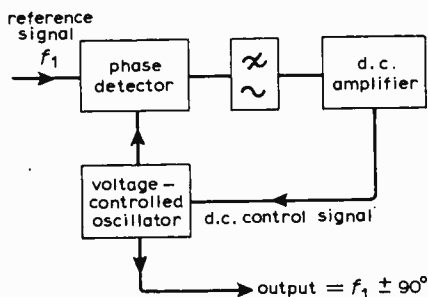

Fig. 10. Phase-locked loop.

This is amplified and applied to the v.c.o. to correct the error. The effective bandwidth can be made small by giving the low-pass filter a cut-off frequency of, say, 1Hz. The v.c.o. and reference, under normal locked conditions, are in quadrature; it follows that a phase-locked loop can also be used as a 90° phase shifter at a fixed frequency.

Conclusion

Until a satisfactory cheap receiver for some form of s.s.b. broadcasting is evolved no move to s.s.b. broadcasting can be contemplated. All the elements exist, and receivers can be made, but not yet at the right price, even on optimistic assumptions about cost savings through quantity production.

If a move to s.s.b. ever does take place then it is likely that some form of modulation compatible with existing a.m. receivers will be adopted. Essential improvements to new receivers will be adequate selectivity, frequency stability, and tunability in the hands of the unskilled.

In the long run, it may be possible to move to pure s.s.b., which is the one system with all the advantages: maximum bandwidth economy, maximum transmitter efficiency, maximum protection from distortion during selective fading, and minimum detector distortion. But, as Lord Keynes was fond of remarking, in the long run we are dead.

References

- Eden, H., "Perspectives of replanning LF/MF broadcasting" *E.B.U. Review*, No. 106A, Dec., 1967.
- Eden, H., "Sound broadcasting coverage and frequency planning in the LF/MF bands". *Telecommunications Journal*, Vol. 39, No. VI, June, 1972.
- Kahn, L.R., "Compatible single-sideband". *Proc. Inst. Radio. Engrs*, 1961, Vol. 49, No. 10.
- van Kessel, T. J., "Compatible single-sideband modulation", *Philips Technical Review*, 1963/4, Vol. 71A.
- Stumpers, F. L. H. M., van Hurck, N., and Voorman, J. O., "A receiver for AM and for single sideband AM with a partially suppressed carrier", *E.B.U. Review*, No. 108A, April 1968.
- Noorgard, "Practical single-sideband reception", *Q.S.T.*, July 1948.
- Netzband, R., "A novel arrangement for the reception of single sideband and double sideband transmissions in AM sound broadcasting", *E.B.U. Review*, No. 114A, April 1959.
- van Slooten, J., "On synchronization of LC oscillators", (Philips) *Electronic Application Bulletin*, June/July 1951, No. 6/7.

S.S.B. Receiver for M.W.

Since the above article by G. Wareham was written a further review of possible single-sideband receiving techniques for broadcasting has come out. "Receiver innovations for future domestic broadcasting" is the title of a paper by J. F. Craine and R. C. V. Macario, presented at an I.E.R.E. conference on Radio Receivers and Associated Systems held at the University College of Swansea (4th-6th July). The paper contains several additional references on this general subject and also mentions a particular s.s.b. receiver for medium waves developed at the College by the authors.¹ Coming in the category of "receivers for base-frequency channels" mentioned by Mr. Wareham, the Swansea design uses many of the principles described by Eden but has other interesting technical features. The local oscillator is phase locked to a pulse train by a sample-and-hold phase-locked loop, and the quadrature detector waveforms are obtained from the same logic circuit that produces the reference pulse train. When the receiver is tuned the output changes abruptly from station to station instead of gradually as in conventional sets.

Reference

- Craine, J. F. and Macario, R. C. V. "A crystal controlled phase-lock method for the reception of amplitude-modulation and single-sideband broadcasting", *E.B.U. Review*, No. 131-A, February 1972.

News of the Month

America assists at A.T.C. West Drayton

The Civil Aviation Authority is about to negotiate a series of contracts with industry which will result in a powerful computer complex and urgently needed other facilities being installed for the London Air Traffic Control Centre at West Drayton. The announcement from the Authority makes little mention of the much publicized Mediator system which was to solve London's air traffic problems for a while. It would appear that Mediator has not lived up to expectations.

Heart of the new system will be a control processor developed in America for the Federal Aviation Administration. This system, called the 9020D, is built up around I.B.M. computers and is already operating successfully at several locations in America. The F.A.A. "have generously" agreed to provide their developed software for the system.

It is planned that Marconi, major contractors in the Mediator project, are to play a big part in interfacing the 9020D with existing equipment at West Drayton. Marconi will also be responsible for expanding their Myriad 1 installation for middle air space control.

The new installation, which should be operational by 1975, will cost more than £20M, about £15M of which will be spent with British industry. Most of Britain's £15M share will be spent on displays and associated computing systems.

In the longer term the Civil Aviation Authority will be placing early contracts for a study of a replacement system capable of meeting the needs of the heavier traffic of the later 1980s and 1990s.

Oil rig tropospheric scatter system

The radio division of Marconi Communication Systems Ltd is to supply a tropospheric scatter radio link which will carry both data and voice communications for BP's Forties Field oil rigs in the

North Sea. The system, which will cost over £350,000, will link the oil rigs with a shore terminal at Brimmond Hill, near Aberdeen. The data link will allow the shore station to control various processes in the oil production unit and still be able to monitor these processes by telemetry. Tropospheric scatter dish terminals will be installed on two oil production platforms, to act as main and standby links which will then be linked to each other, and to two other production platforms by microwave, line-of-sight, radio paths. The complete system will be designed to operate unattended, with control being exercised from a main station at Dyce, near Aberdeen, and connected to Brimmond Hill by a microwave radio link.

To obtain the high circuit availability needed for the system, quadruple diversity, using both space and polarization diversity will be used. This enables an almost 100% availability to be achieved using a single frequency in each direction.

The radio terminal at Brimmond Hill will have two 9m (30ft) dishes. The low-level drive and receiver systems will use the new Marconi equipment, type H3122, operating around 2.5GHz and capable of providing 132 telephone channels. Two 1kW power amplifiers, type H3722, will be employed as main and standby transmitters. This amplifier uses a klystron for the output stage, and is designed for long periods of unattended operation.

Computer news distribution

Computers to provide government ministries and agencies with more rapid and efficient news services from its central news bureau in Bonn, are to be used by the West German state press agency. The minicomputer-based system, which will come into operation this autumn, is now being developed at Honeywell's engineering centre at Hemel Hempstead, Herts. Reports covering worldwide political, economic and other news are received

continuously from German and foreign press agencies on teleprinters and centralized at the agency editorial room before distribution to officials. Under the new system, the reports will appear simultaneously on seven monitor screens in the editorial room and be held in the computer's disc files. Through a special display system with distribution keyboards, editors will be able to call up news items that catch their eye, edit the messages and dispatch them over direct lines to 37 remote teleprinter terminals installed in various government offices from the Chancellor's down, or to a line-printer for subsequent courier or mail distribution. The system has been designed to enable news reports to be stored for 24 hours for further analysis or eventual return to the editors for error-checking.

Two Honeywell 316 computers will be installed — one in use and the other on standby. The display units on the third floor of the press agency building will be remote from the computers which will be installed in the basement. The system handles initially six incoming 50-baud telegraph lines, one incoming 75-baud line, twelve outgoing 200-baud lines via modems, and twenty-five 50-baud lines.

Small pocket calculator

Sinclair Radionics has introduced a very slim pocket calculator measuring only 140 × 50 × 9.5mm (5½ × 2 × 0.375 inches) which will retail for £79. It has an eight digit GaAs (seven-segment) display and can operate in fixed or floating point modes. Functions available are add, subtract, multiply, divide, and constant storage.

Two main problems had to be overcome before the case depth could be reduced to 9.5mm: a special keyboard had to be designed and a way had to be found to power the calculator from miniature mercury button cells. The first problem was overcome by using the printed circuit board itself as the lower contacts for the push-buttons. The case is therefore constructed in two halves with the push buttons in the upper half and the printed circuit in the lower. Supplies to the push buttons are connected by little pieces of spring material soldered to the printed circuit board which make with contacts in the upper half of the case; this looks rather crude.

The problem of using batteries with very limited power capacity was overcome by switching off supplies to the calculator chip (made by Texas Instruments) in between clock pulses and relying on the gate capacity of the m.o.s.f.e.t.s on the chip to store the information. The ratio between on and off periods varies between 1:3 and 1:40, depending on what the calculator is doing. Further power saving was achieved by using a low clock pulse rate, by causing

the display to flash after a few seconds of steady reading and by powering the display directly from the battery eliminating series dropper resistors which dissipate power. We understand that Texas Instruments do not guarantee correct operation of their calculator chip under the pulsed power supply conditions present in this calculator. However, Sinclair give a five-year guarantee which covers everything except misuse.

We thought the on/off switch (a piece of plastic pushing a piece of bent flat spring material on to the printed circuit board) and the fixed/floating point selector switch were difficult to operate and were not examples of particularly good engineering practice.

The production tests carried out on the calculator do not include a temperature cycling test which is unfortunate as if the calculator were left in direct sunlight, say on the back seat of a car, for a few hours one could not be sure that it would still function correctly.

Sinclair Radionics are to be congratulated for a brave and clever design but it is a pity that more attention was not paid to detail and sound engineering principles.

Wireless across the water commemorative stamp

Every year the Barry College of Further Education commemorates the first wireless transmissions across water, carried out by Marconi and Kemp from Lavernock Point, near Barry, to Flatholm Island in the Bristol Channel and Brean Down in Somerset. This year, the 75th anniversary, the college is making available a commemorative first day cover service from Flatholm Island. The Post Office is issuing a 7½p stamp, commemorating this first transmission over water (one of four new commemorative stamps).

The college, for the modest fee of 20p, will post an envelope attractively printed in two colours bearing the commemorative 7½p stamp on the first day of its issue (Sept. 13th) and franked with a specially designed postmark from Flatholm Island to your own address. Readers wishing to take advantage of this service should send a crossed postal order or cheque made payable to The Barry College F.E.R.S. at the following address: Barry College of Further Education, Colcot Rd, Barry, Glamorgan. Make sure you include your own name and address.

Constant-voltage transformer

A constant-voltage transformer developed by Bradenberg Ltd (Thornton Heath) has been granted a patent in America. The transformer has a high leakage reactance, with at least two secondary windings. The combined output of the two secondary windings is related so that if the output from one increases the output from the other decreases. The main output from

the transformer can therefore be altered by varying the load on one of the secondaries. This property is used by a feedback control system to stabilize the output from the transformer.

A. D. Blumlein

"Some originators are commemorated in the name of a device, law or discovery — for example, the Hartley circuit, Ohm's law, and the Hall effect. Unfortunately none of Blumlein's frequently mentioned inventions bear his name. Although it appears here and there in the literature, probably very few even of the workers in the same field, and especially younger ones, have any idea of how far ahead he was in so many important developments. How many present-day stereophony fans, for example, realize that the system of recording was invented by Blumlein in 1931?" So wrote M. G. Scroggie in his appreciation "The genius of A. D. Blumlein" in our September 1960 issue.

Alan Dower Blumlein, who was chief engineer of the E.M.I. Research Department at Hayes, Middlesex, was killed in 1942 when making tests of airborne radar in a Halifax bomber. He was then only 38 and yet had no fewer than 132 patents granted to him.

Flat plates under tension have been in use for the past 15 years for the production of reverberation in studios. An electrolytically deposited thin foil of gold replaces the usual steel plate in the EMT 240 reverberation unit from F. W. O. Bauch. The unit, whose principle was outlined in "Progress in Acoustics" (Wireless World, November 1971), was seen at this year's Association of Professional Recording Studios exhibition. It measures only 25 × 26 × 12 in and will be available at the beginning of December. The problems overcome in production include the reduction of unwanted damping and the difficulty of maintaining reverberation time at high frequencies — problems inherent in a plate of low surface density.

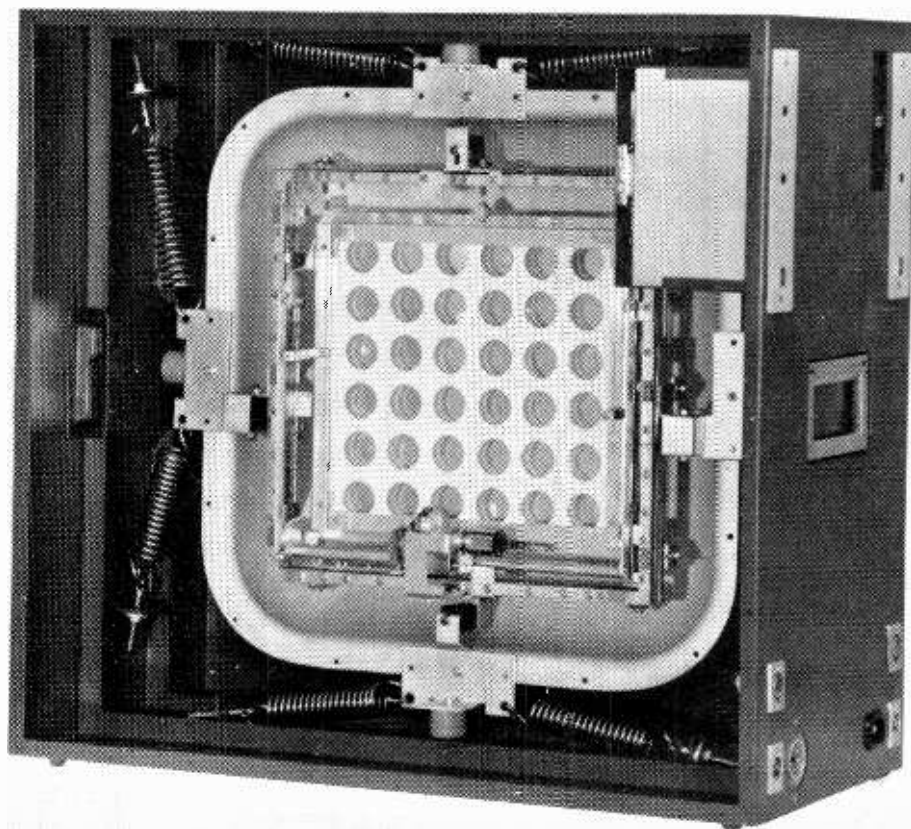

We are glad to learn that F. P. Thomson is preparing a biography of Blumlein. All who had personal contact with him — however small — or would like to give an assessment of his position in the history of technology, are invited to write to Mr. Thomson at 39 Church Road, Watford WD1 3PY, Herts.

What a laugh!

Mullard are running a "smilers competition" for service managers and engineers in the radio and TV trade. Most people have some funny personal experience (a smiler), frequently connected with their work, and competitors are required to present a smiler in not more than 250 words. The following prizes will be awarded for the funniest: 1st: A luxury weekend for two (two nights) at a top hotel in the West End of London including entertainment. (Alternatively the winner may take the equivalent value in cash.) 2nd: A gold watch. 3rd: A 35mm automatic camera. In addition there will be 12 consolation prizes of record tokens. Entries (complete with home address and employers name and address) should be sent to Mullard Ltd., Sales Promotion Department, Mullard House Torrington Place, London, WC1E 7HD. Closing date for the competition is September 30th 1972.

Circuit Ideas

Schmitt trigger with op-amp

Any operational amplifier can be used as an efficient and precise Schmitt trigger. With a conventional Schmitt trigger circuit the two triggering voltages V_{t1} and V_{t2} are not only very temperature dependent and widely spread, but it is also difficult to know their exact value. Using an operational amplifier overcomes all these problems. Both V_{t1} and V_{t2} can be set accurately, either very close together (a few millivolts difference) or far apart and are much less temperature dependent.

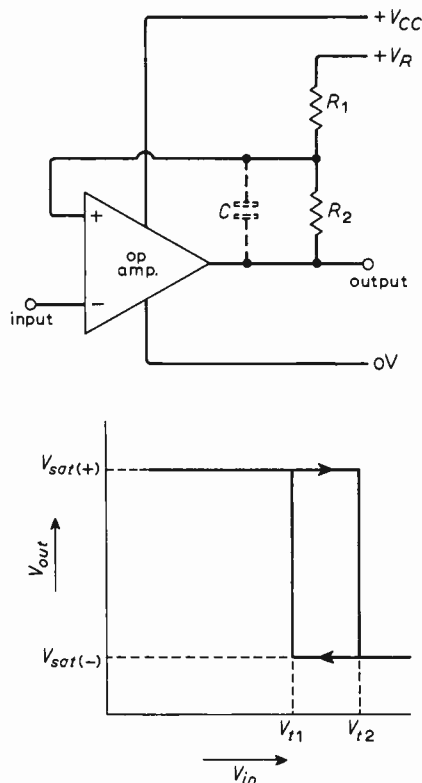

For the circuit to work $(R_1 + R_2)/R_2$ must be less than the open-loop voltage gain of the amplifier. Capacitor C ensures that the slew rate is as large as possible, but it should be carefully selected — above a certain value it may cause oscillation. If maximum slew rate is not required it can be omitted.

J. Rowley
St Andrews
Bristol

Simple voltage stabilizer

A simple series voltage stabilizer which gives good supply ripple reduction, while using less components than similar circuits achieving the same result, is shown. The circuit maintains a constant potential across the zener diode by virtue of the near constant current through it. Departures from this constant current are sensed and an error signal derived.

Component values for a 6.8-volt supply are indicated. The output regulation from zero to a full load current of 100mA is 0.3%, with nominally zero temperature coefficient, and changes of the input

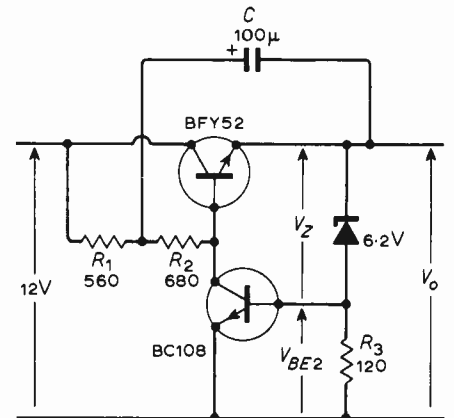

base current and current change in R_2 is ideally zero. A direct current source would work wonders for the input regulation. If reduced ripple performance is acceptable the bootstrap capacitor can be omitted, and R_1 and R_2 replaced by a single component.

P. S. Ewer
Great Bookham
Surrey

Electronic thermometer uses i.c.

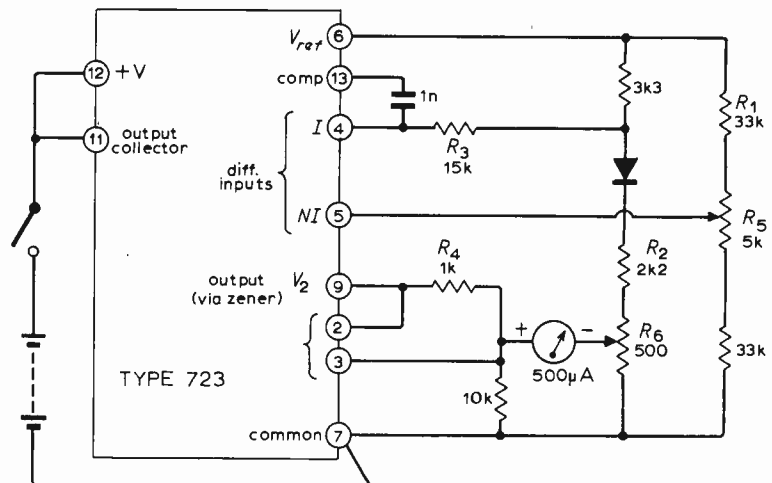

The surface-temperature thermometer using discrete components described by L. Nelson-Jones (*Wireless World* vol.75 1969 pp.180-3) measures the forward voltage drop of a silicon diode, which varies essentially linearly with temperature. A circuit to do this can be constructed very easily using the 723 integrated circuit voltage regulator. Compared with the original circuit, this offers:

- independence of meter resistance — no need for thermistor compensation
- use of a less-sensitive meter without affecting diode current
- lower current consumption — about 3mA.

If the meter current is set to zero at 0°C

by R_5 , at higher temperatures the regulator amplifier forces current through the meter and the lower part of R_6 until the potential difference produced in the latter equals the decrease in diode voltage and rebalances the bridge. Thus R_6 controls the temperature span. Resistor R_1 may need adjustment for some diodes; R_2 raises the input voltage to the differential amplifier — the makers specify 2V; R_3 approximately equalizes the source resistance of the two inputs; and R_4 , with the internal current-limiting circuit, protects the meter from severe overload.

B. E. Kerley
Coulson
Surrey

The Ubiquitous Phase Sensitive Detector

Applications and principle of operation

by K. L. Smith,* Ph.D.

One might ask wherein lies the ubiquity of the phase sensitive detector circuit, considering that in many cases a mumble of "I've never used one" might be heard. One reason is that it parades under many a pseudonym and perhaps a list of the more common might ring a mental bell or two—phase sensitive rectifier, homodyne, synchrodyne, product detector, synchronous rectifier, correlation detector, coherent detector, etc. The number and variety of applications in which phase sensitive detectors (p.s.d.s) turn up are also pretty widespread. The use of product detectors in single-sideband receivers is well known. Here the carrier is reintroduced to the sideband and audio outputs are obtained by multiplying together this locally-generated carrier and the sideband components. Actually, the precise phase of the reference carrier compared to the original at the transmitter is not as critical as it would have to be with double-sideband suppressed-carrier signals. In the latter case a true p.s.d. would be needed where the phase of the reference would require careful control.

This brings us to the synchrodyne receiving method—a technique not new to *Wireless World* readers.¹ A true p.s.d. is used to demodulate an a.m. r.f. signal. The necessary reference signal with the correct phase is obtained from the carrier by phase locking a local oscillator to it. Bandwidth filtering is obtained after the detection process. (This property of being able to set bandwidths after the detector is a big advantage of the technique.)

There has been a rise into prominence of phase-locked loops in electronic circuitry. An example of this was mentioned above in connection with the synchrodyne. As another example a spot frequency synthesizer can be constructed giving crystal-controlled frequency stability at, say, 30 frequencies in the short-wave band but employing only one crystal. The block diagram of Fig. 1 shows how this is achieved.

The voltage-controlled oscillator is phase locked to each harmonic of the 1-MHz crystal. By applying the two signals to the p.s.d., a direct control voltage is produced proportional to the phase difference between the oscillator and crystal oscillator harmonic, at least for small phase differences. Thus when the oscillator is tuned to

lock in at each harmonic, the output is frequency stable—more than that, it is phase stable with respect to the crystal.

The full analysis of the operation is complex. The time constant of the d.c. amplifier can be critical; so is the lock-in range. This kind of loop stability problem is common to all negative feedback loops and correct design requires some thought.

In physics laboratories the p.s.d. turns up in scanning spectroscopy. A beam of visible or infra-red radiation being analysed is interrupted by a chopper blade to produce an alternating signal, then amplified and passed to the p.s.d. A reference signal, whose phase can be varied, is obtained from the chopped beam and fed into the other terminals. This method is referred to by physicists² as a 'homodyne amplifier' system. The great advantage is that the effective noise bandwidth can be set by filtering after the detection process, a con-

siderably easier job than trying to use selective audio amplifiers before the detector. (Just consider the difficulties with tuned amplifiers of 2-Hz bandwidth if the chopper frequency tends to drift.)

A big improvement in the ability to detect small signals became available for radio astronomical observations when Dicke published his radiometer scheme. This was based on alternately switching the aerial and a standard noise source into the receiver and switching a detector after the video amplifier in step with this, i.e. a p.s.d., to produce a resultant output—Fig. 2. The channel containing the standard noise source produces a known 'temperature' and the other channel can be some cosmic source being picked up by the aerial. If gain drifts slightly, both channels are affected accordingly, but the relative measure remains the same. Again, system bandwidth can be set after the detector.

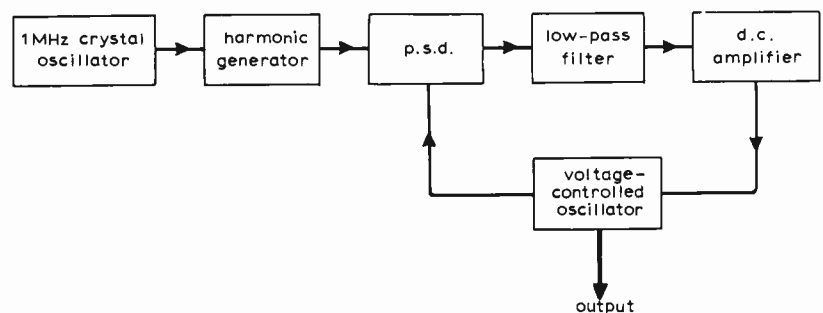

Fig. 1. In some frequency synthesizers, an oscillator is phase locked to a particular harmonic of a crystal oscillator according to the frequency required.

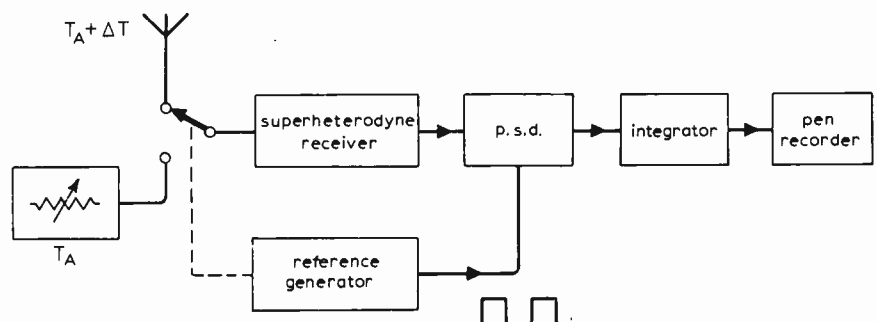

Fig. 2. Although sensitivity is reduced in the Dicke radiometer system, the gain in stability more than compensates.

*Electronics Laboratory, University of Kent.

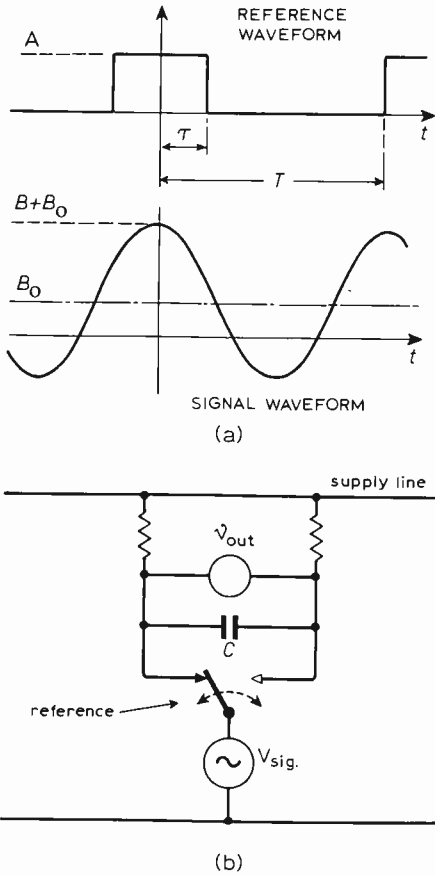

Fig. 3. The phase sensitive detector is typically a synchronous switch. A reference waveform operates the switch and the circuit should not be sensitive to changes in its amplitude.

Because radio astronomical signals are wideband noise, the minimum change in source noise temperature observable, ΔT , is improved by having a large bandwidth, B , before the detector and a small bandwidth after it. The latter requirement is the same thing as saying that the detector is followed by a filter with a long integrating time, τ . In fact, by considering the statistics of the wideband noise signals, we find

$$\Delta T = \frac{2T}{\sqrt{B\tau}}$$

Filtering after phase sensitive detection to obtain a large τ is relatively simple, as we shall see later.

It is a reminder to look back at the list at this point, and to realize that the old synchronous vibrators were a typical p.s.d. sys-

*The number '2' is a particular value; other slightly different constants appear according to the circuit used.

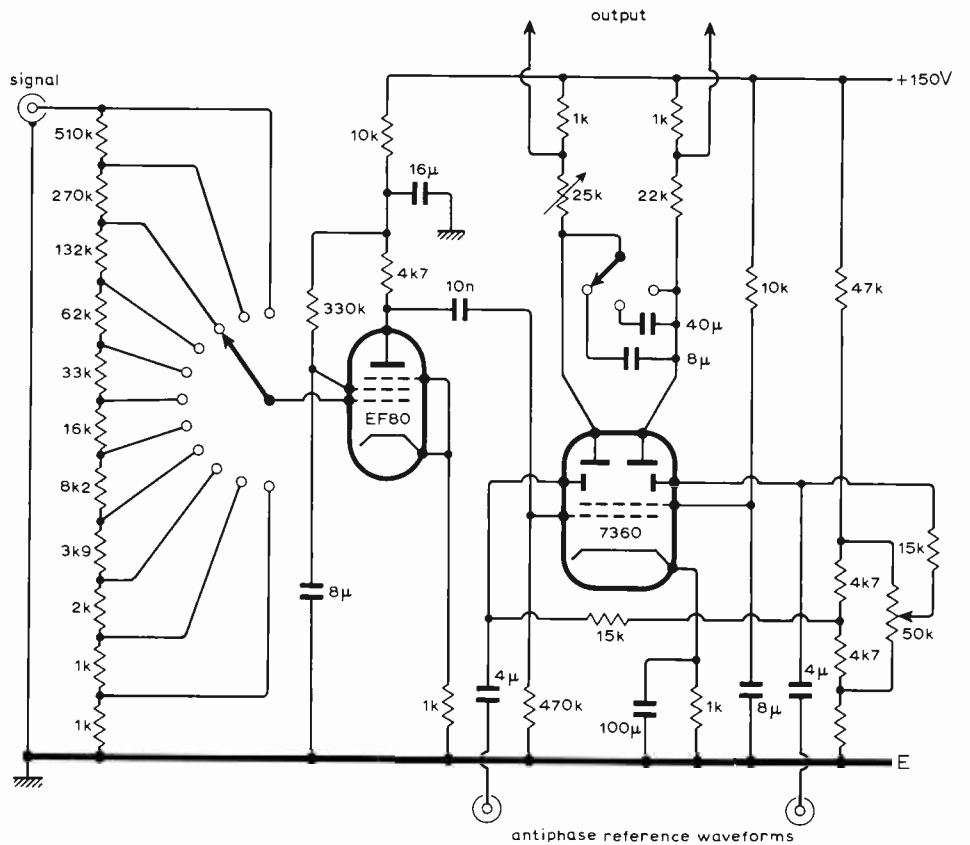

Fig. 4. Practical phase detector using beam-switching valve.

tem, with the secondary of the transformer switched in phase across the smoothing filter. This switched or synchronous rectifier idea is often found in the armoury of the control engineer with his servo systems. The error signal is often in the form of a phase shift in one waveform relative to another and a p.s.d. gives a d.c. output proportional to this. (Actually it is proportional to the cosine of the phase angle in the case of sine wave signals, see appendix.)

Perhaps there has been a television receiver in your workshop with something a bit odd happening in the flywheel sync circuit. (You might remember the swearing involved!) Right there was the p.s.d. of course, which should have been keeping the timebase oscillator phase locked to the sync pulses. Quite unabashed we find p.s.d.s all over colour television sets. The colour burst during the period of one of the porches on the video waveform is used to phase lock a crystal oscillator in the receiver. The local oscillation is used to demodulate the chrominance signals in a pair of p.s.d.s.³

Working near the limits set by random noise, a periodic signal might be completely buried. Any signal variation which at first sight looks completely random (on a cathode ray tube, for instance), may have a periodic component. If then we phase detect with a reference signal whose frequency is chosen to equal the periodic component we know or suspect is in the noisy signal any output, after a suitably long integration time to reduce the random noise, indicates the presence of such a component. A remarkably small signal in a huge amount of noise has been detected in this way. In fact the Dicke radiometer mentioned earlier operates this way.

The p.s.d. used to dig out a weak signal in noise is working as a correlation detector, and the process is known as cross-correlating the signal and reference. Of course, we could have taken the original noisy signal and correlated it with a time delayed version of itself (auto-correlation). If there is no periodic signal component, then there will be one large output when the delay is zero and all the variations are in phase. Nothing further is obtained as output whatever the delay, because no phase coherence is obtained again. But if there is a periodic component, every time the delay is one period, there is an in-phase condition at the detector and therefore an output. The output is a series of spikes, separated by the periodic time. (A very informative article appeared in *Wireless World* on this topic in March 1955. In it, James Franklin discussed the recovery of signals by correlation methods and gave some very interesting applications, including one where a tape recorder was used as a correlation analogue computer.)

Rather closely connected with correlation, at least it would seem from the mathematical form, is an operation known as convolution. There are subtle differences however. Two functions can be convolved and in effect one is smoothed by the other. If one function has a number of fine details, these are lost if the other is a broad one. Convolution is in fact a scanning of one function by another and multiplying. So was correlation, but there one looked for similarities in the two functions. In convolution one function is reversed, then scanned across the other. An aerial beam of known distribution, looking at a source sweeping through would be a convolution process;

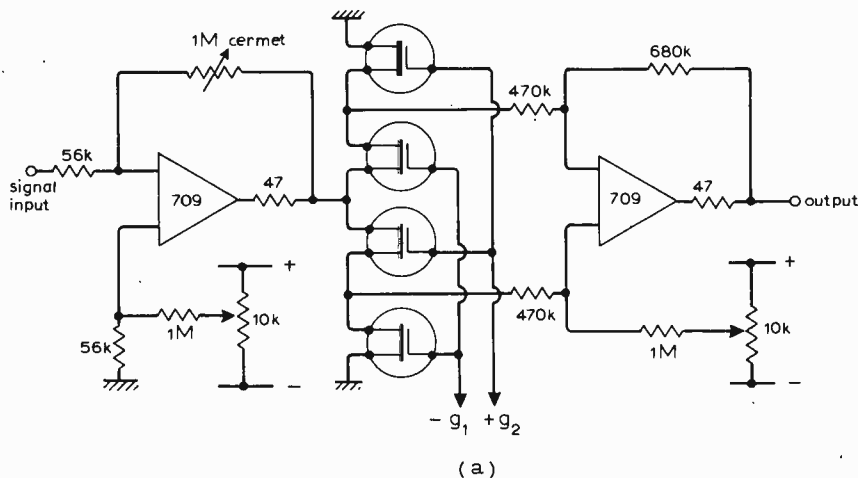

(a)

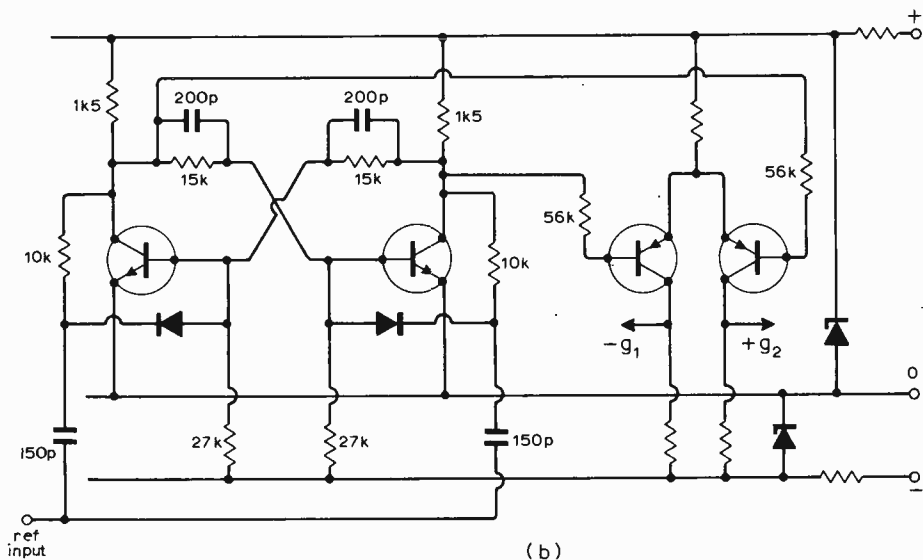

(b)

Fig. 5. This circuit—used in an astronomical radiometer—has a full-wave synchronous bridge detector. Output amplifier effectively produces a single-ended output from its balanced input signal. (Circuit of (a) connects to that of (b) at points g_1 and g_2).

so would a spectral line scanning across a slit at the output of a spectrograph.

The p.s.d. is well suited to demonstrate correlation and convolution of periodic signals. If one waveform is fed to the reference input and the other to the signal input and a slight difference in frequency exists, then as the waveforms slowly sweep 'past' each other (as seen on a double-beam oscilloscope for instance), the output of the p.s.d. will represent the correlation function of the waveforms, or the convolution if one wave shape is imagined as folded back on itself, i.e. is the reverse of the function being studied. So one can use the p.s.d. to demonstrate (and perhaps to use seriously in a system) the convolution and correlation of periodic functions, two very important ideas in modern communication theory.

Practical detectors

The basis for a phase sensitive detector system is a one-way (half-wave) or two-way (full-wave) switching circuit. Mechanical switches or commutators can be and have been used, but electronic switching is much more precise and convenient. The principle is illustrated in Fig. 3. If the switch is operated by the reference waveform in synchronism with the signal, then one half

cycle only will pass to charge capacitor C in the case of half-wave switching, Fig. 3(b). In the case of full-wave switching, C is charged by both half cycles; all the positives going one way, all the negatives the other. †

Some time ago a very useful valve appeared (designed for colour television purposes) known as a beam deflection tube (R.C.A. 7360). In this device two deflector

†So far it appears that just a switching on and off is involved. In fact the signals in the two channels are multiplied together. While it is easy to see that a switch can have zero or unity gain, and therefore that the output will be the signal multiplied by a reference signal of either zero or unity, it may not always be obvious that in detectors with a sinusoidal or otherwise non-rectangular reference that the output is the product of the inputs. Looking on the p.s.d. as an analogue multiplier removes this problem. While this is not the place to discuss techniques of analogue multiplication, one particular realisation may be helpful. Imagine a signal attenuated in a potentiometer, the output being the product of tapping position—expressed as a fraction of the whole—and input signal amplitude. Multiplication by a second, reference signal is then achieved by applying it to the potentiometer wiper electromechanically. In the special case where the reference is rectangular, one is operating a switch that is either on or off, the product being either zero or finite (unity where there is no gain), depending on whether the switch has zero or unity gain. One can visualize this as multiplication by thinking of the two extremes of potentiometer tap as representing zero and unity gain.

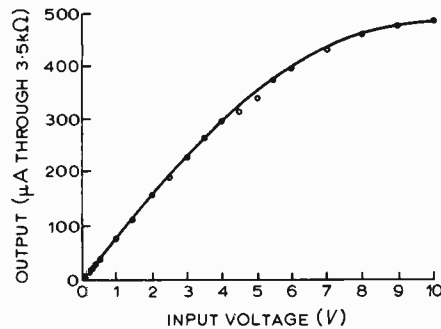

Fig. 6. The 7360 circuit of Fig. 4 is linear up to 3 or 4V input to the grid of the valve to accommodate large noise amplitudes.

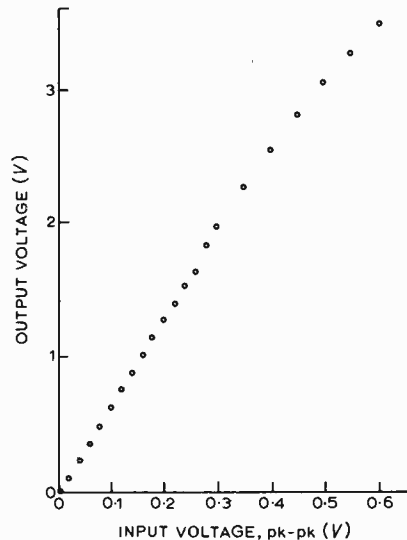

Fig. 7. Linearity of the solid-state circuit measured for one gain setting of the driver amplifier. Graph indicates order of performance one would expect in a reasonable phase detector.

plates, rather like those in a cathode ray tube, switch the beam of electrons alternately from one anode to another. If the reference waveform is applied to the plates and a signal to the control grid, synchronous rectification takes place at the anodes. The circuit of a balanced full-wave phase-sensitive detector using this valve is shown in Fig. 4. The detector was actually developed and used with success in an infra-red spectrographic system.

Of course there is some advantage in using semiconductor devices. A number of switching f.e.t.s are available now and can be very successfully used in p.s.d.s. The second practical example given here is working at the moment in a radiometer for solar and atmospheric observations. The arms of the bridge of f.e.t.s—Fig. 5—are alternately switched by the reference waveforms in synchronism with the signal waveform at the output of the first 709 operational amplifier. In effect this means that the second operational amplifier input is alternately switched in phase across the output terminals of the first one. Filter C_T , R_T forms the integrator.

A p.s.d. worth its salt should have a fairly wide linear working region so that large noise amplitudes on small signals can be

accommodated without running the circuit into overloading. The circuits I have described produced the input-output linearity curves shown in Figs 6 and 7.

Perhaps this outline discussion of the phase sensitive detector begins to show some of the ubiquity. There is much more that could be said and a suggestion for further reading is given at the end of the references. The appendix gives a few sums for those interested, but the arguments are not necessary for the main ideas of my text.

Appendix

The two instantaneous values of the reference and signal waveforms occurring at every instant, are multiplied together by a phase sensitive detector, hence the other name—product detector. If the reference signal is $f_1(t)$ and the main signal is $f_2(t)$, the output of the p.s.d is $f_1(t)f_2(t)$ in the absence of overloading and before smoothing or integration. The area under the product curve of $f_1(t), f_2(t)$ is

$$\int_{-\infty}^{\infty} f_1(t)f_2(t) dt$$

It is somewhat arbitrary to go ahead and talk about the average value of $f_1(t)f_2(t)$ if there is just one occurrence (for instance, the average value of the above integral over an infinite time is zero), but if the functions are periodic with period T the average value is

$$\frac{1}{T} \int_{-\tau/2}^{\tau/2} f_1(t)f_2(t) dt$$

and this is the value that would be produced across, say, a large smoothing capacitor at the output of the p.s.d.

Suppose $f_2(t)$ is a periodic reference signal of symmetrical square waveform. Fourier tells us

$$f_2(t) = A_2 \left(\frac{1}{2} + \frac{2}{\pi} \cos \omega t - \frac{2}{3\pi} \cos 3\omega t + \frac{2}{5\pi} \cos 5\omega t - \dots \right)$$

where A_2 is the amplitude, the first term a d.c. component and the remainder the fundamental and odd harmonics. If $f_1(t)$ is a sine wave signal with amplitude A_1 and phase angle ϕ , then

$$f_1(t) = A_0 + A_1 \cos(\omega t + \phi)$$

Multiplying $f_1(t)$ and $f_2(t)$ we get a series whose terms are all zero on average, except for the first two

$$\frac{A_0 A_2}{2} + \frac{A_1 A_2}{\pi} \cos \phi$$

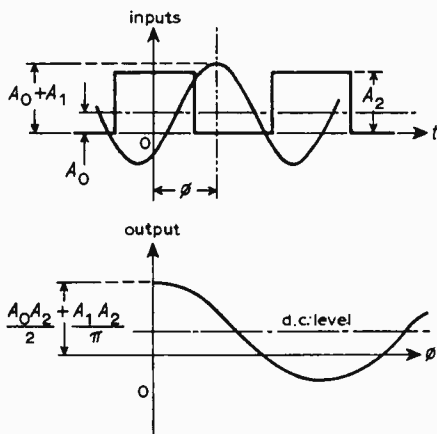

Fig. 8. The p.s.d. as a phase meter—with sinusoidal input the output is proportional to the cosine of ϕ (about any d.c. level).

This shows that the output varies with the cosine of the phase angle and has maximum and minimum values of $\pm A_1 A_2 / \pi$ (assuming from now on that the d.c. components of both signals are zero) as Fig. 8 shows.

Suppose that the input signal $f_1(t)$ is also a symmetrical square wave, then the output will be the average value of

$$f_1(t)f_2(t) = \left[\frac{2A_1}{\pi} \cos \omega t - \frac{2A_1}{3\pi} \cos 3\omega t + \dots \right] \cdot \left[\frac{2A_2}{\pi} \cos(\omega t - \phi) - \frac{2A_2}{3\pi} \cos 3(\omega t - \phi) \dots \right]$$

Now more of the terms multiply up to give a contribution to the averaged output

$$\frac{4A_1 A_2}{\pi^2} \cos \phi + \frac{4A_1 A_2}{9\pi^2} \cos 3\phi + \frac{4A_1 A_2}{25\pi^2} \cos 5\phi + \dots$$

and by trigonometry, the sum of this series can be shown to be

$$\frac{4A_1 A_2}{\pi^2} \left(1 - \frac{2\phi}{\pi} \right)$$

for values of ϕ between 0 and π radians, and

$$\frac{4A_1 A_2}{\pi^2} \left(\frac{2\phi}{\pi} - 3 \right)$$

for values of ϕ between π and 2π radians. In words, the output is a triangular wave as ϕ varies, as shown in Fig. 9.

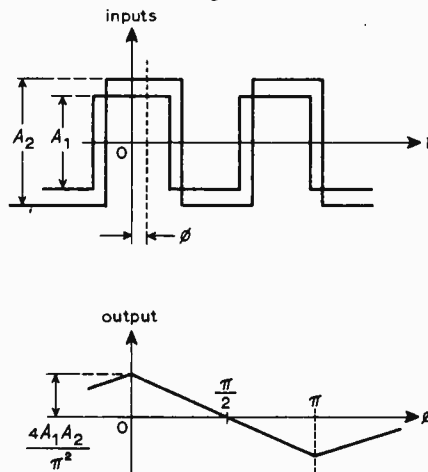

Fig. 9. In the case of square waves, the p.s.d. output is directly proportional to ϕ .

Rewriting the phase changes in terms of time variations $\cos(\omega t - \phi)$ can be written $\cos(\omega(t - \phi/\omega))$ or writing ϕ/ω as τ , and applying this idea to any function, we can finally write $f_1(t - \tau)$ for the signal and interpret it as function $f_1(t)$ sweeping along the axis as τ varies. This is true even if the function is no longer periodic. This idea of a whole function sweeping along the axis might be a little difficult to visualize, but think of a wave motion, for instance, and it should become clearer. Fig. 10 shows this for $f_1(t - \tau)$. If τ is added to t , that is $f_1(t + \tau)$, then the function moves along in the other direction, as indicated in Fig. 11.

It is now possible to see what happens when one function is scanned across either a replica of itself or a different function; an action obtained in practice, for example, by using a variable delay network in one channel. The mathematics of this is fairly easy to see now, so consider the following average

$$C_{11}(\tau) = \frac{1}{T} \int_0^T f_1(t)f_1(t + \tau) dt$$

where T is the period.

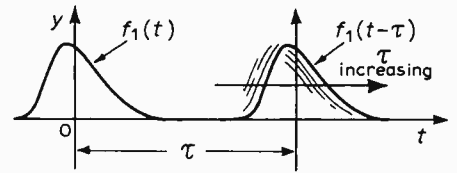

Fig. 10. As τ varies, the whole function $f_1(t - \tau)$ moves along the t axis.

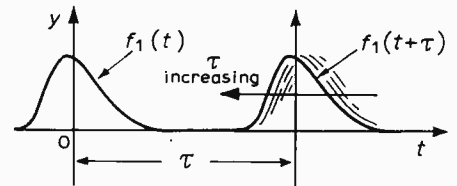

Fig. 11. With the opposite sign, the direction of movement of the function with τ is reversed.

Function $C_{11}(\tau)$ is known as the autocorrelation function; in this case, for periodic functions. Two different functions multiplied and averaged in this way gives the cross-correlation function

$$C_{12}(\tau) = \frac{1}{T} \int_0^T f_1(t)f_2(t + \tau) dt$$

These operations search out any similarities in the functions, hence give a measure of the correlation between them. They are very significant in statistical communication theory and crop up in such applications as digging out small signals in large amounts of noise.

Mathematically speaking, convolution has a lot in common with the ideas mentioned above. There is one important difference however. One of the functions is reversed—hence the name of the operation, to convolve—and then it is scanned to produce the product which is finally integrated and averaged

$$\text{convolution, } C_{1-2} = \frac{1}{T} \int_0^T f_1(t)f_2(\tau - t) dt$$

Typical convolutions include the case of a spectral line scanning past a slit, or a distant radio source distribution being scanned by an aerial beam. Of course, convolution gives an output not primarily dependent on any similarity between the functions (contrast correlation), but is a kind of 'smoothing' of one function by the other.

The phase sensitive detector shows all these operations for periodic functions.

References

1. 'Cathode Ray' The Synchrony, *Wireless World*, vol. 53, 1948, pp. 277-81.
2. R. A. Smith, F. E. Jones and R. P. Chasmar, *The Detection and Measurement of Infra-red Radiation*, Oxford, 1957.
3. S. C. Ryder-Smith, The P.A.L. Colour TV System, *Wireless World*, vol. 73, 1968, pp. 628-33.

A good general reference to the kind of material discussed in the appendix and which I have found very readable is chapter 7 in *Information Transmission Modulation and Noise* by Mischa Schwartz (McGraw Hill).

10 - 80 Metre Amateur Transceiver

3. Transmitter section

by D. R. Bowman, G3LUB

This month the transmitter section of the transceiver will be described. It will be recalled that last month, in the receiver description, the sections which were common to both transmit and receive were dealt with. These were the local oscillator synthesizer, the b.f.o. and the 9MHz crystal filter. The complete circuit diagram for the transmitter side of the equipment is given in Fig. 13 (overleaf). As with the receiver each subsection will be described in turn.

Balanced modulator

The filter system for generating single sideband signals is used in the transceiver and as the i.f. filter and amplifier is centered on 9MHz then so must the s.s.b. generator. Diodes D_1 and D_2 are part of the balanced modulator which is driven by the amplifier (Tr_1). It is not essential to include this amplifier to bring the b.f.o. output up to a suitable level to switch the diodes, but flexibility and transmit/receive isolation would suffer without it.

The diodes D_1 and D_2 were selected for forward and reverse resistance matching from a handful of point contact germanium devices. If it is found that adjustment of R_8 does not minimize the carrier then it may be necessary to change the value of one or other of the 470Ω bridge arm resistors. Note that a small variable capacitor C_7 connected from one (or the other) side of L_{27} secondary may help to reduce the carrier still further. Full details of the alignment procedure will be given in the final part of this series next month. Having achieved a carrier balance (which basically means negligible 9MHz being fed to the isolation/switching stage Tr_2) when audio signals are introduced into the diode pair 9MHz r.f. energy proportional to the audio applied will be fed to Tr_2 . This is double sideband suppressed carrier. Another way to think of it is to consider the diodes and resistors (D_1 , D_2 , R_7 , R_8 and R_9) as a bridge which is balanced until audio is fed to the diode junction. The unbalance is proportional to the audio and constitutes a d.s.b. signal.

Microphone amplifier

The microphone amplifier is rather more complex than is usual, but this circuit allows the use of a much wider range of microphone signal levels and avoids the use of an expensive microphone and audio-to-balanced modulator transformers. The

microphone has a single pole changeover switch incorporated (S_2) which is used to mute the microphone on receive and to operate the transmit/receive relay (RL_1) on transmit. The first stage of the microphone amplifier Tr_8 consists of a high impedance, common source f.e.t. amplifier with the preset audio gain control R_{32} in the drain circuit.

The author would like to explain this further. When the transceiver is in operation there are many occasions when it is necessary to vary the output power and the internal gain (drive) to make up the losses incurred on the high frequency bands. Only one level of audio is correct for the modulator and the level once set for a particular microphone, should require no further adjustment. This level is the one that produces least audio distortion, but not so low that the carrier suppression to sideband output ratio deteriorates. The common practice of using the microphone gain to alter the drive level is one of the factors causing many of the poor quality signals to be heard on the amateur bands today.

Returning to the description of the microphone amplifier we find that following the audio preset gain control is a common emitter amplifier Tr_7 . This in turn drives an emitter follower Tr_5 whose low output impedance approximately matches the input impedance of the double diode balanced modulator. The r.f.c. (L_{28}) is in circuit in order to isolate the microphone amplifier from the 9MHz r.f. voltage. The network consisting of R_{39} and C_{30} connected between the microphone and the gate electrode of Tr_8 is included to keep r.f. voltages out of the microphone amplifier's circuit.

The author's cheap crystal microphone, which has an output of about 5mV (peak-to-peak), produces an output across R_{18} of about 1.5V peak-to-peak. This audio level seems to be about optimum.

Carrier insertion

Many transceivers include a carrier insertion control which allows a small leak of b.f.o. voltage past the balanced modulator and crystal filter. This is done to provide a tuning signal and also because it is sometimes possible to receive s.s.b. on normal a.m. receivers not equipped with a b.f.o. In the author's experience the inclusion of such a facility can easily lead to a deterioration in sideband suppression and sometimes en-

hances the residual carrier even when the operator is intending to use s.s.b. As there are now very few amateurs who operate on the 10 to 80m bands who are not equipped with s.s.b. detectors it has been decided not to include this facility.

Tone generator

An audio tone generator consisting of Tr_3 and Tr_4 in a free running multivibrator circuit, is included for tuning, aerial adjustments and the like. The audio waveform the multivibrator produces is approximately square, being very rich in harmonics, and utterly useless for two-tone measurements. The tone generator is connected into the microphone amplifier and is brought into operation by switching the h.t. line. This reduces the chances of unwanted signals entering the microphone amplifier.

Pre-filter i.f. amplifier

The pre-filter i.f. amplifier Tr_2 does three things. It provides some gain, it matches the modulator to the filter and acts as a signal path switch. The stage is biased on by switching the base bias resistor R_{11} to the +11V transmitter supply line. When the transceiver is in the receive mode this stage has no bias and therefore passes no signal.

Crystal filter

The filter is common to both transmit and receive and has already been described as part of the receiver. It is obviously a reciprocal unit as it has to pass signals in both directions (one for transmit and one for receive). No signal switching as such is carried out, the direction of signal flow being determined by enabling or disabling appropriate amplifier stages.

Post-filter i.f. amplifier

Following the filter is a further i.f. amplifier (Tr_6) which is switched in the same way as the pre-filter amplifier. The stage is needed to raise the signal to the required level for the transmitter balance mixer, to act as a signal switch and to provide electrical gain control. The stage also matches the 560Ω filter impedance to the relatively high impedance of the mixer. The mixer drain coil, L_{41} , has a bifilar wound secondary which produces the push-pull drive required by the mixer. The resistor R_{19} is taken to the +11V transmit supply line thus allowing transmit/receive control.

The automatic load control circuit (a.l.c.) will be described in conjunction with the power amplifier except to point out that by varying the d.c. bias on gate 1 (Tr_6) the overall gain of the stage can be controlled. No screening was required between the input and the output of this amplifier, but it is advisable either to keep the input leads very short or to use miniature coaxial cable. Needless to say a gate protected m.o.s.f.e.t. device is used.

Transmitter balanced mixer

The aim of the transmitter mixer is to frequency translate the 9MHz s.s.b. signal to the appropriate amateur band 10 to 80m. In the translation process it is essential to keep the level of all unwanted spurious to a minimum. For h.f. band operation spurious levels of 50dB below the peak s.s.b. output is normally considered adequate, but when the transceiver is used in conjunction with a 2m transverter very much greater attenuations are to be expected. Dual gate f.e.t.s (Tr_9 and Tr_{10}) are used in the mixer circuit in view of their excellent spurious free per-

formance and their substantially square law transfer characteristic. The high impedance of the two isolated gate electrodes allows considerable signal to injection oscillator isolation together with a very low i.o. drive requirement. The decision to use two devices in a balanced circuit was prompted by the extra 20dB i.f. and harmonic rejection which such a circuit affords. Examining the circuit of the balance mixer Tr_9, Tr_{10} , one notices R_{38} the i.o. rejection balance potentiometer. In practice there seems little advantage in making this variable and some space saving is to be had by leaving the component out. With a symmetrical layout the balance is quite adequate. The i.o. drive voltage is fed in parallel to the gate 2 electrodes via C_{27} (Fig. 11) from the frequency synthesizer which was described in part 2 of this series.

The drain-to-drain switched load coils are carefully balanced using bifilar winding on 20 to 80m and straightforward centre taps on 10 and 15m. This circuit is tuned with a front panel control which is ganged with the receiver's r.f. circuits and the driver's apode

tuning capacitor. In operation it is necessary to set this control only somewhere near the operating frequency.

This is the last of the signal processing stages. All that is now required is to increase the signal level using a linear power amplifier.

Driver stage

Very careful consideration was given to the design of this stage as at first sight there seems little advantage in using valves. Assuming that a valve output power amplifier is to be used then the driver stage will only be required to provide voltage gain. The mixer's output can be expected to vary from band to band by at least 20dB and the driver stage is the best point in the circuit to make up this difference by incorporating a manual gain control.

The simplest system would have used a wideband 3 to 30MHz amplifier, but as the transceiver is expected to cover only a small number of 500kHz wide frequency windows

(continued on page 374)

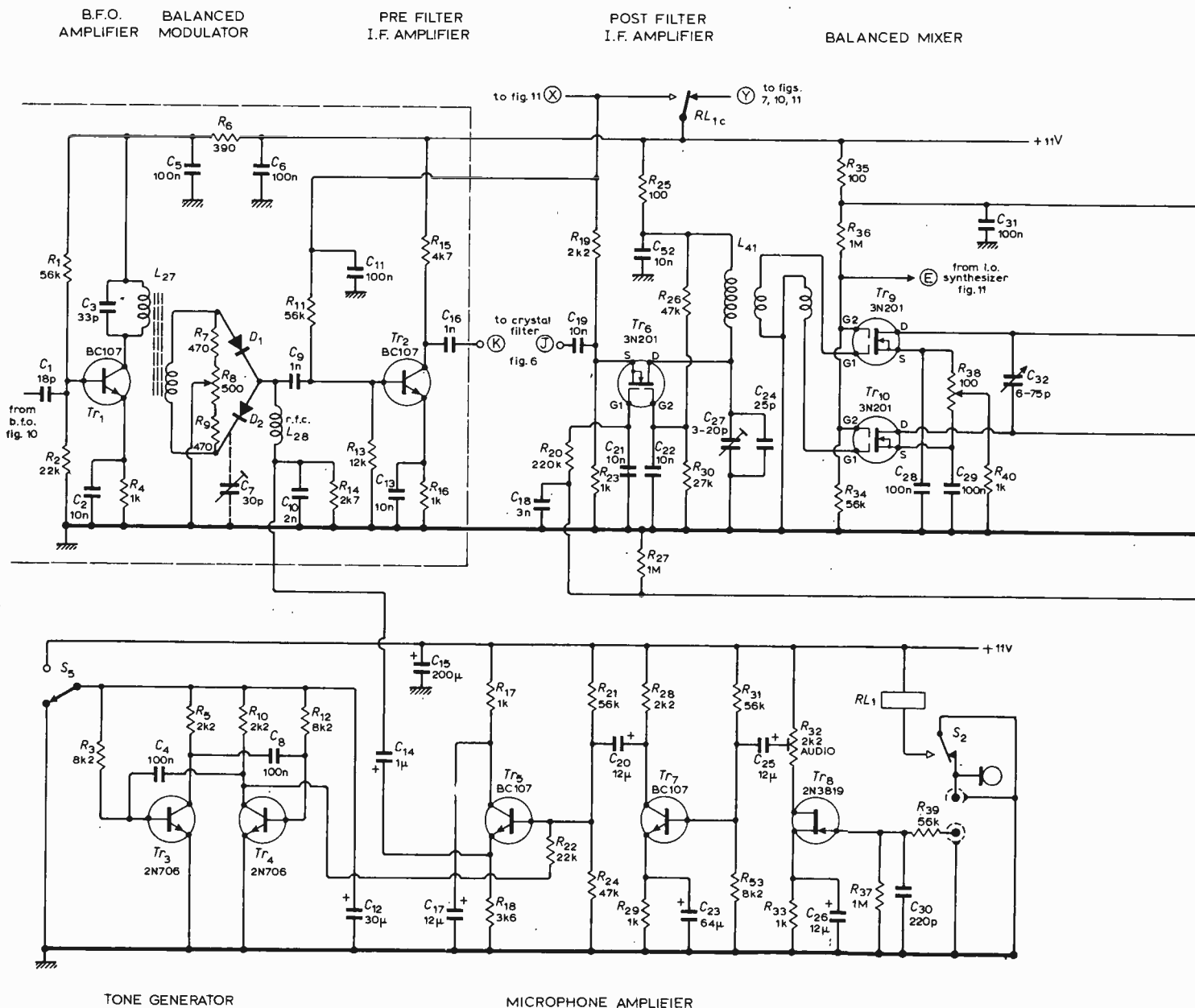

Coil Winding Details

transmitter section

balanced modulator

*L*₂₇, 9MHz: Primary, 40 turns 34 s.w.g. Secondary, 10 turns of 34 s.w.g. bifilar wound. Use a screening can, iron dust core and a 47pF parallel capacitor. (Author modified a 10.7MHz i.f. transformer.)

*L*₂₈, r.f.c.: standard former (see last month) close wound full length with 34 s.w.g. wire. Use an iron dust core.

transmitter mixer

*L*₂₉, 80m: Primary, 60 turns 34 s.w.g. bifilar wound. Secondary, 50 turns of 34 s.w.g. wound over primary but insulated from primary by four layers of paper. Connect 56pF in parallel.

*L*₃₀, 40m: Same construction method as *L*₂₉. Primary, 45 turns of 34 s.w.g. bifilar. Secondary, 40 turns.

*L*₃₁, 20m: Same construction method as *L*₂₉. Primary, 16 turns of 28 s.w.g. bifilar. Secondary, 24 turns of 28 s.w.g.

*L*₃₂, 15m: Same construction method as *L*₂₉. Primary, 10 turns of 28 s.w.g. bifilar. Secondary, 12 turns of 28 s.w.g.

*L*₃₃, 10m (a): Same construction method as *L*₂₉. Primary, 8 turns of 28 s.w.g. centre tapped. Secondary, 10 turns of 28 s.w.g.

*L*₃₄, 10m (b): Same as *L*₃₃.

*L*₃₅, 80m: 60 turns of 34 s.w.g. with 56pF in parallel.

*L*₃₆, 40m: 45 turns of 34 s.w.g.

*L*₃₇, 20m: 16 turns of 28 s.w.g.

*L*₃₈, 15m: 10 turns of 28 s.w.g.

*L*₃₉, 10m: 8 turns of 28 s.w.g.

There is no *L*₄₀ coil.

i.f. transformer

*L*₄₁, 9MHz: Primary 40 turns of 34 s.w.g. Insulate this winding with three layers of paper. Secondary, 50 turns 34 s.w.g. bifilar wound.

p.a. r.f.c.

*L*₄₂: A former 100mm (4in) long by 18.75mm (0.75in) diameter is wound with a total of 250 turns of 34 s.w.g. wire in five close wound sections. Each section is spaced 3.2mm (0.125in) from the next. The sections are 150, 50, 25, 15 and 10 turns. This construction is observed to help eliminate any self resonances which might occur in the amateur bands.

pi tank

*L*₄₃, 10m: Six turns of 16 s.w.g. wire wound on a 18.75mm (0.75in) diameter with a winding length of 25.4mm (1in). Remove former as the coil is self supporting.

*L*₄₄, 80-15m: Use a former 50.8mm (2in) long by 31.75 (1.25in) in diameter. Wind 20 turns spaced 1 turn apart and tap at the following points

| | |
|---------------|---------------|
| 80m - 9 turns | 20m - 4 turns |
| 40m - 8 turns | 15m - 3 turns |

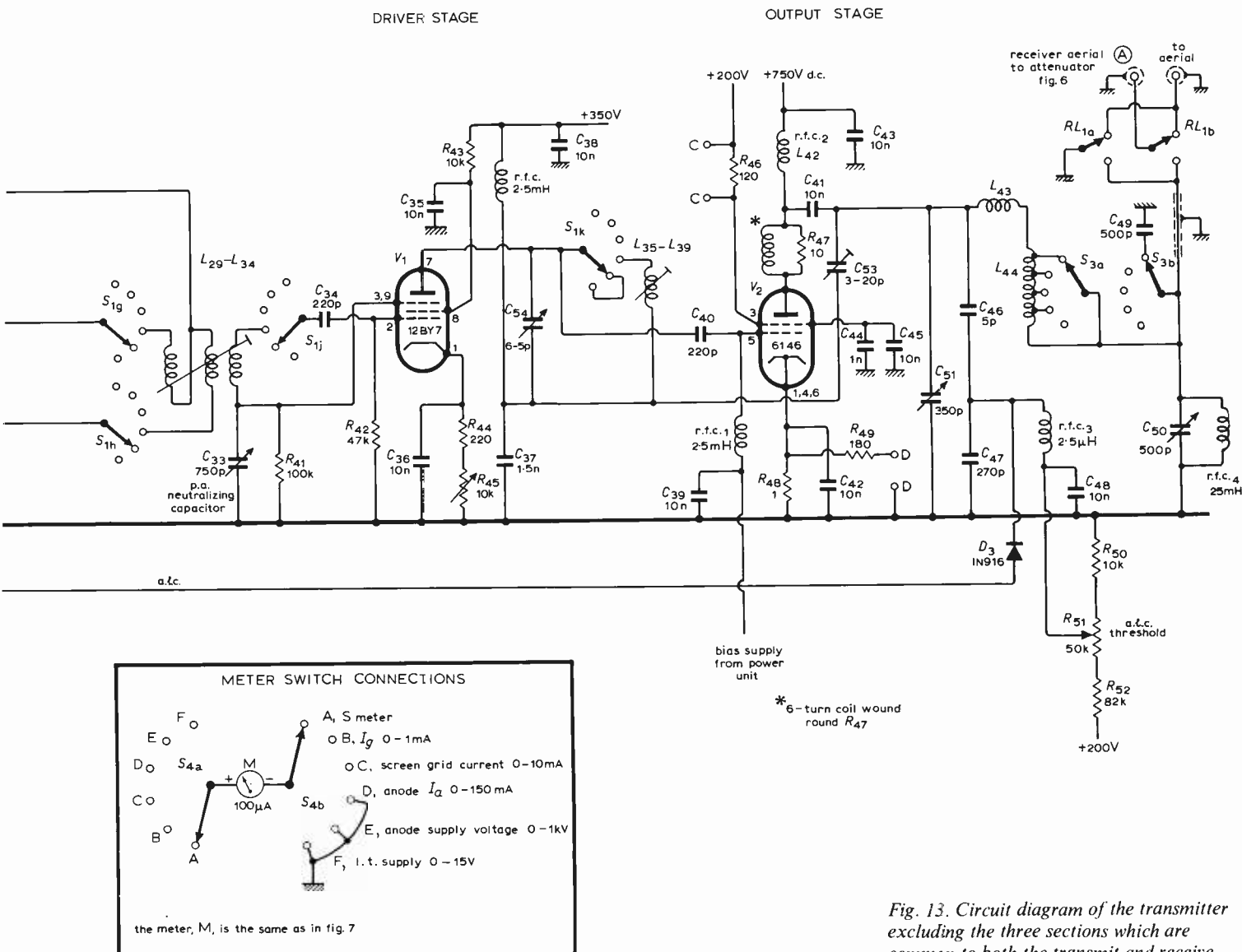

Fig. 13. Circuit diagram of the transmitter excluding the three sections which are common to both the transmit and receive function. Capacitor *C*₅₂ is 100n not 10n as shown on the drawing.

there is a considerable advantage in making the amplifier tuned. This reduces the spurious outputs to a low level and also permits a reduction in the number of components.

Finally it was decided to use a valve because of the ease of multiband range changing. The inter-stage filter circuitry being very much simpler than that required when using a bipolar amplifier. The use of f.e.t.s was considered, but devices with the necessary voltage and frequency response are expensive. Many types of valve would fulfil the requirements of this stage but the 12BY7A has been chosen because it lends itself to mobile operation as the heater can be series connected and used on a 12V supply.

The author has experience of building many linear valve driver stages and decided from the onset that it was advisable to incorporate neutralization, even when using tetrodes and pentodes. From the practical aspect suppressor grid neutralization has much to recommend it. A screen can be mounted right across the valve socket and does not have to be pierced by an anode lead, possibly at a high potential, to feed the neutralizing circuit. The suppressor grid is at 0V d.c. and is on the grid side of the partitioning screen. The alignment procedure will be dealt with next month.

The control of the gain is quite a critical operation as almost all amplifiers have only one optimum operating condition which gives high gain together with low distortion. Some circuits can produce distortion products that have levels higher relative to the required signal than those generated in the p.a. G. R. B. Thornley, G2DAF, published¹ a circuit using an unbypassed cathode potentiometer system which relied upon negative feedback to produce the reduction in gain. This is a very good method but has the practical disadvantage of requiring a high power carbon potentiometer which the author has found difficult to obtain. The circuit that the author finally used works well as the performance figures will testify and in this circuit a wirewound potentiometer is used. The circuit relies for the control of gain on the reduction of transconduction which occurs when the anode current is progressively reduced.

Power amplifier

In the first issue of this series the reasons for choosing a valve for the power amplifier were outlined. The type 6146 was chosen as the best of a number of valves having anode dissipation ratings in the range 20 to 25W. This particular valve is a convenient size and in order to save height in the author's

transceiver the 6146 is mounted horizontally. This procedure also provides ease of access to both the grid and anode circuitry.

The p.a. circuitry is quite standard using a common cathode connected valve with stabilized 200V screen and preset grid 1 bias supplies. The output circuit consists of a special r.f.c. fed h.t. supply, the r.f. being coupled from the anode to the aerial via a pi matching circuit. The anode current as such is not monitored, the h.t. supply being 750V positive relative to the chassis. Instead the cathode current is measured and, in addition, using a six-position switch, the same meter is used to monitor screen and grid 1 currents, signal strength on receive, h. t. and l.t. voltages. The amplifier is bridge neutralized and if the adjustments are made on 10m the p.a. will remain stable on all the other bands. The author was rather short of space and therefore used an available 500pF capacitor as the pi tank loading control and, as a result, found on 80m that an extra 500pF shunt capacitor was required. An extra wafer on the pi tank inductance switch was used to switch this extra capacitance into circuit. If 1000pF variable capacitor is available this could be used thus avoiding the need for the extra switch wafer and 500pF capacitor. Capacitor C_{51} is termed the tuning control and is used in conjunction with C_{50} the loading capacitor to achieve the required anode-to-aerial match. It will be noticed that an r.f.c. is connected across the r.f. output from the p.a. This is a safety precaution introduced to short circuit any d.c. voltage that could appear on the aerial if the blocking capacitor C_{41} should develop an electrical leak.

Automatic load control

The power amplifier is required to amplify the s.s.b. signal without introducing distortion, but in practice it is found that unwanted spurious are generated. If the signal being fed to the amplifier has its unwanted sideband 45dB below the wanted output the process of power amplification will introduce distortion products whose amplitudes may be considerably greater than this figure. Intermodulation products are rarely more than 30dB below the required output even in a well designed power amplifier. Quite frequently the tendency to overdrive a transmitter increases these products to such an extent that they spread for many thousands of hertz on either side of the required signal. Assuming that the amplifying valve is correctly biased, i.e. operating in class AB1, then these distortion products will be well down and they will only increase excessively when the control grid is driven positive on speech peaks. This distortion is caused by the abrupt change in input impedance of the p.a. valve which therefore produces peak clipping. Incidentally the harmonic output also increases as a result of this overdrive. If one examines the speech waveform it will be seen that the average power is very low if care has been taken to avoid the speech peaks from exceeding the zero bias point. It is found that an increase of about 3dB in effective signal strength can be obtained if a form of compression is introduced into the system. One note of warning. The author has never found a.l.c.

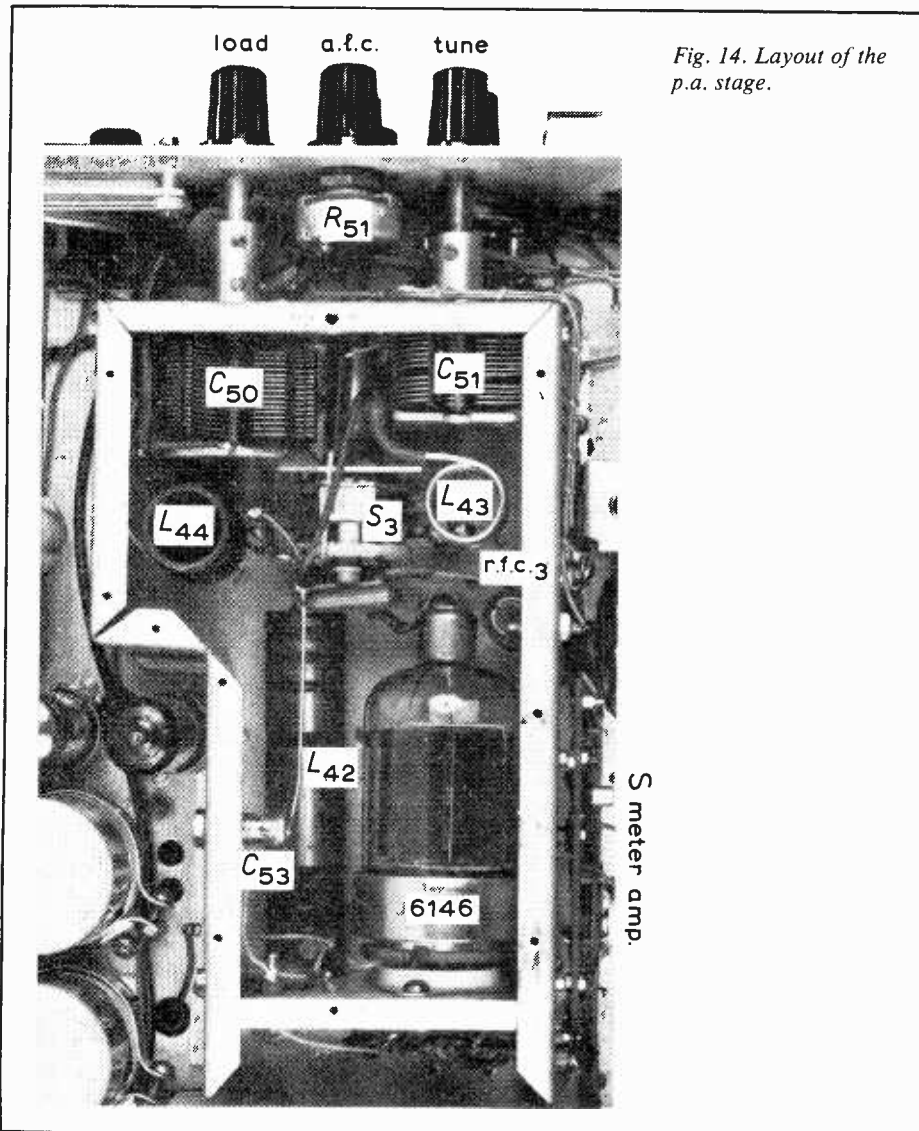

Fig. 14. Layout of the p.a. stage.

an advantage except under the most adverse communication conditions because although the effective power increases, the speech intelligibility tends to decrease.

The method used to produce this compression is to rectify the signal peaks of the output signal and use the negative voltage thus produced to adjust the gain of the post filter amplifier. A backing off potentiometer is incorporated so that the point at which the compression comes into play can be adjusted. The main use for a.i.c., the author has found is when driving a high power linear which uses 4CX250 tetrode valves which produce excessive distortion with even the slightest positive grid drive.

Components List

transmitter section

| | |
|-------------------------|-----------------------------|
| C ₁ 18p SM | C ₂₈ 100n DC |
| C ₂ 10n DC | C ₂₉ 100n DC |
| C ₃ 33p SM | C ₃₀ 220p MC |
| C ₄ 100n DC | C ₃₁ 100n DC |
| C ₅ 100n DC | C ₃₂ 6-75p G |
| C ₆ 100n DC | C ₃₃ 750p V, J |
| C ₇ 30p T | C ₃₄ 220p SM* |
| C ₈ 100n DC | C ₃₅ 10n DC* |
| C ₉ 1n MC | C ₃₆ 10n DC* |
| C ₁₀ 2n DC | C ₃₇ 1.5n SM* |
| C ₁₁ 100n DC | C ₃₈ 10n DC* |
| C ₁₂ 30μ E | C ₃₉ 10n DC* |
| C ₁₃ 10n DC | C ₄₀ 220p SM* |
| C ₁₄ 1μ E | C ₄₁ 10n 2kV, M |
| C ₁₅ 200μ E | C ₄₂ 10n DC |
| C ₁₆ 1n MC | C ₄₃ 10n 1kV, M |
| C ₁₇ 12μ E | C ₄₄ 1n DC* |
| C ₁₈ 3n DC | C ₄₅ 10n DC* |
| C ₁₉ 10n DC | C ₄₆ 5p SM* |
| C ₂₀ 12μ E | C ₄₇ 270p SM* |
| C ₂₁ 10n DC | C ₄₈ 10n DC* |
| C ₂₂ 10n DC | C ₄₉ 500p SM* |
| C ₂₃ 64μ E | C ₅₀ 500p V |
| C ₂₄ 25p SM | C ₅₁ 350p 1kV, V |
| C ₂₅ 12μ E | C ₅₂ 100n DC |
| C ₂₆ 12μ E | C ₅₃ 3-20p T* |
| C ₂₇ 3-20p T | C ₅₄ 6-75p G |

SM - silver mica, DC - disc ceramic, MC - miniature ceramic tubular (low stray capacitance), E - electrolytic, M - mica, T - trimmer, G - C₃₂ is ganged with C₅₄, and is also ganged with C₁₁ and C₁₂ of Fig. 6, J - Jackson type U101, * - 350V d.c. working, 1kV - 1kV working, 2kV - 2kV working, V - variable.

| | |
|-----------------------|----------------------------|
| R ₁ 56k | R ₂₈ 2.2k |
| R ₂ 22k | R ₂₉ 1k |
| R ₃ 8.2k | R ₃₀ 27k |
| R ₄ 1k | R ₃₁ 56k |
| R ₅ 2.2k | R ₃₂ 2.2k P |
| R ₆ 390 | R ₃₃ 1k |
| R ₇ 470 | R ₃₄ 56k |
| R ₈ 500 P | R ₃₅ 100 |
| R ₉ 470 | R ₃₆ 1M |
| R ₁₀ 2.2k | R ₃₇ 1M |
| R ₁₁ 56k N | R ₃₈ 100 P |
| R ₁₂ 8.2k | R ₃₉ 56k |
| R ₁₃ 12k | R ₄₀ 1k |
| R ₁₄ 2.7k | R ₄₁ 100k |
| R ₁₅ 4.7k | R ₄₂ 47k, 2W |
| R ₁₆ 1k | R ₄₃ 10k |
| R ₁₇ 1k | R ₄₄ 220 |
| R ₁₈ 3.6k | R ₄₅ 10k P |
| R ₁₉ 2.2k | R ₄₆ 120* |
| R ₂₀ 220k | R ₄₇ 10, 1W |
| R ₂₁ 56k | R ₄₈ 1 WW* |
| R ₂₂ 22k | R ₄₉ 180 |
| R ₂₃ 1k | R ₅₀ 10k |
| R ₂₄ 47k | R ₅₁ 50k P, lin |
| R ₂₅ 100 | R ₅₂ 82k |
| R ₂₆ 47k | R ₅₃ 8.2k |
| R ₂₇ 1M | |

P - potentiometer, N - mount close to Tr₂, WW - wire wound, * - monitoring resistors connected to meter switch.

| | |
|-----------------------|------------------------|
| Tr ₁ BC107 | Tr ₆ 3N201 |
| Tr ₂ BC107 | Tr ₇ BC107 |
| Tr ₃ 2N706 | Tr ₈ 2N3819 |
| Tr ₄ 2N706 | Tr ₉ 3N201 |
| Tr ₅ BC107 | Tr ₁₀ 3N201 |

| | |
|--|----------------------|
| V ₁ 12BY7 | |
| V ₂ 6146 | |
| D ₁ } matched pair of | D ₃ 1N916 |
| D ₂ } germanium diodes (OA79) | |
| S _{1, G-H} 6 way switch ganged with S _{1, A-F} | |
| S ₂ s.p.c.o. press-to-talk | |
| S ₃ 2 pole, 5 way | |
| S ₄ 2 pole, 6 way meter function switch | |
| S ₅ s.p.c.o. | |
| RL ₁ 12V, 4 pole changeover relay | |

REFERENCE

1. Thornley, G. R. B. "Communications Receivers", R.S.G.B.

(to be concluded)

Sixty Years Ago

August 1912. A note in *The Marconigraph* described successful attempts at determining longitude by measuring the time taken for radio waves to travel. One experiment involved the use of clocks and transmitters at the Eiffel Tower and at Bizerta (Tunis). The Astronomer Royal, Sir George Airy, travelled 22 times between Greenwich Observatory and Valentia (an island off the coast of Kerry) carrying 30 chronometers before he was satisfied that he had correctly measured the longitude of the island.

A portable wireless installation was also described (no doubt the grandfather of Clansman). "Devoid of complications, extremely portable and easy to manipulate, the importance of the knapsack station cannot possibly be exaggerated".

Four men, each carrying a load between 20 and 30 lb, could transport the station. The transmitter was built round a 6V ignition coil in a box weighing "only 11 lb". The receiver employed a carborundum detector with a "jigger"**, tuning condenser and four dry cells which could be "switched off and on when required". The sectional aerial was constructed mainly from aluminium tube and was complete with guys, its height was 30ft. Of the performance the makers (Marconi) said "owing to the short wavelength employed, which is so widely different from that in ordinary use, these stations are practically immune from interference". Ah well — happy days!

* R.F. transformer for coupling the closed circuit to the open aerial. — Ed.

H.F. Predictions — August

The high level of solar activity reported last month continues, producing HPFs and FOTs very similar to those of 1971. The four years or so of a sunspot maximum period seem to have a secondary cycle of solar activity with two or three peaks and the present peak should be the last of these. The three years or so following sunspot maximum appear to have a cycle of ionospheric disturbances, again with two or three peaks and the first of these seems to have built up over the last few months. Although the chart lowest usable frequencies (LUFs) are calculated for high-power point-to-point telegraphy the most favourable time for any type of service is when they are about 2MHz or more below the optimum traffic frequency (FOT). Note however that this applies only to reception in the U.K. while HPF (highest probable frequency) and FOT are the same for both directions of a circuit.

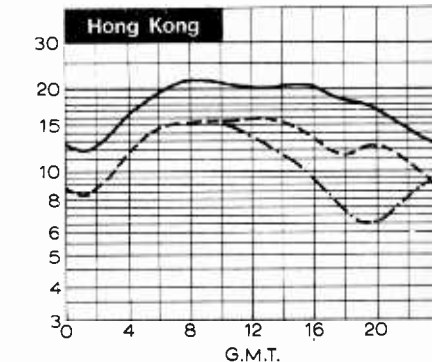
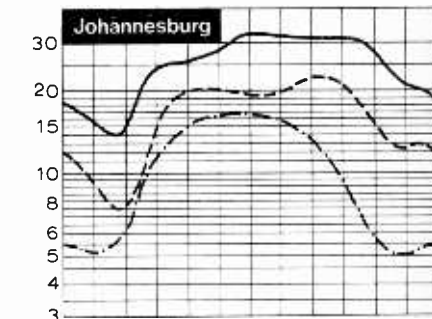
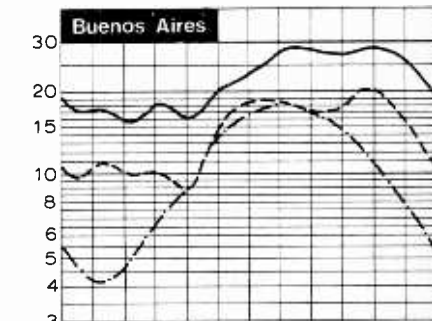
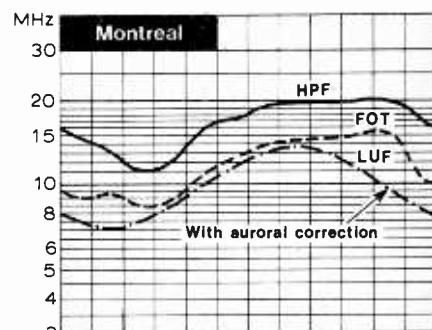

Communication '72 —

Communication '72, the exhibition and conference held in Brighton recently, was a complete success. More than 8,000 visitors came to the exhibition, far exceeding expectations, while the conference attracted just over 500 delegates.

Business at the exhibition was brisk with all exhibitors establishing contact with new potential customers or making sales on the spot. One large company claimed that by 3 o'clock on the afternoon of the first day of the event they had recovered their outlay. It was a pity that some of the big names (such as Pye, Marconi and Plessey) decided not to take part. The decision could well not have been in their best interests.

We have said a good deal in the past few months about the relative merits of small and large exhibitions, and events at Brighton seemed to indicate that we were thinking along the right lines. In this context we make a plea to ETV Cybernetics Ltd who organized Communication '72. Limit the exhibition to communications and do not allow fringe interests to creep in, no matter how tempting it may be to do so. If this is not done Communication '74, and succeeding exhibitions, will become large, diverse and devalued.

Another request, but this time to the management of the Metropole Hotel where the exhibition was staged: please do something about the public address system in the exhibition hall, it did not befit a *communications* exhibition.

A total of 33 papers were delivered at the conference which was jointly organized by *Electronics Weekly* and *Wireless World*. The quality of the papers ranged from poor to excellent but the former were in the minority. Three highlight papers — which were very good — were given by eminent personalities on topics of importance (forecasting the data communication needs of the country; achieving area coverage for point-to-point communications; and how the Army test equipment for military use). In this last paper it was suggested during question time that designers of equipment for military purposes should experience the conditions under which their equipment has to operate — a sobering thought for many a slide rule manipulator.

We hope that the small exhibitions like Seminex, Communication '72 and the newly announced Microwave International '72 are the way exhibitions will go in the future.

Items of interest seen at the Brighton exhibition

Readers can obtain copies of the conference papers for £15.50 per complete set of 33 papers or £5.25 for the papers (11) delivered on any one of the days of the conference. Exhibition visitors and others who left their names at the conference desk need only confirm their enquiry by post to secure priority. Other orders will be dealt with in strict rotation. Cheques should be made payable to IPC Business Press Ltd and included with orders to F. H. Paul, Seminars Manager, IPC Electrical-Electronic Press Ltd, Dorset House, Stamford St, London SE1 9LU.

The rest of this report is devoted to descriptions of items of interest seen at the exhibition.

20-1000MHz receiver

Watkins-Johnson displayed an impressive range of receivers among which was their model 565 which employs five plug-in tuning heads (20 to 90, 90 to 260, 200 to 425, 235 to 500 and 500 to 1,000MHz) and provides a.m., f.m., c.w. and pulse reception. Any one of four preset bandwidths can be selected by a front-panel-mounted switch and can be chosen from the following six, 10, 50, 200 and 300kHz and 1 and 3MHz. If wished any non-standard i.f. bandwidth between 10kHz and 3MHz

can be provided at extra cost. Up to 100kHz bandwidth crystal filters are used and for the higher bandwidths LC circuitry is employed. The 565 receiver gives a typical 3rd order intermodulation intercept point of -5dBm referred to the input of the receiver. Thus, two -40dBm signals within the input passband produce a 3rd order intermodulation product which is 70dB below the level of the input signals. Worst case 3rd order intermodulation performance is specified as an input intercept point of -10dBm .

The 565 receiver is provided with a built-

in spectrum display unit which gives a visual display of signal activity over a frequency range of up to 1.5MHz on both sides of the tuned frequency. The sweep width of the display is continuously variable by means of a front-panel control up to the 3MHz maximum dispersion. A 21.4MHz crystal controlled marker oscillator built into the display may be used to indicate the exact centre of the receiver's i.f. passband. By providing the marker oscillator, the need for a tuning meter is eliminated.

A carrier operated relay (c.o.r.) in the receiver has an adjustable threshold control and a separate release delay switch so that the release time can be set to approximately 0.5, 5 or 15s. The relay has d.p.d.t. contacts which are brought out to the rear-panel. Audio squelch is provided with the threshold set by the c.o.r. threshold control. There is no delay, however, in blanking the audio output following the loss of the input signal. The output of the receiver's video amplifier is also located on the rear panel. The receiver operates from a 115 or 230V a.c., 50-400Hz power supply. Watkins-Johnson Company, 6006 Executive Blvd., Rockville, Maryland 20852, U.S.A.

WW 517 for further details

Modulation meter

The Dymar a.m./f.m. modulation meter type 1785 is intended to measure the depth of modulation or frequency deviation of transmitters. It is operated either from a.c. mains or from its own rechargeable battery and as such is equally suitable as a laboratory instrument or as a portable field servicing equipment.

The frequency range covered (30 to 480MHz) is the whole of the v.h.f. band and extends into the u.h.f. The sensitivity over the whole of this range is better than 2.5mV in 50Ω (-40dBm) which permits loose coupling to the transmitter under test.

The instrument is designed for measurements on narrow deviation transmitters in mobile and portable radio-telephones, the most sensitive deviation range being 3kHz. The local oscillator has low

residual f.m. noise of typically 44dB below 3kHz.

Auxiliary outputs are provided both at the intermediate frequency (500kHz) for viewing the modulation envelope and at audio frequency for measurement of distortion. Dymar Electronics Ltd, Colonial Way, Radlett Road, Watford, Herts WD2 4LA.

WW519 for further details

100W s.s.b. radiotelephone

Murphy Telecommunications introduced a compact s.s.b. radio-telephone based on the s.s.b. module which was described in the July 1971 issue of *Wireless World* by Dr. R. C. V. Macario. Nearly all the internal circuitry is common to both transmit and receive. Two basic models are available, the 1602, which provides 25W p.e.p., and the higher power 2002, which delivers 100W; both models will operate from either a 12 or a 24V d.c. supply. A mains-powered version is available for base station use.

| | |
|---|--|
| frequency range | 1.6 to 16MHz |
| no. of channels | 6 in a band of ± 300kHz |
| controls | volume-on/off, channel select, press-to-talk, mute (option), clarifier (option) |
| weight receiver | 4.7kg (10.35lb) |
| aerial input sensitivity | 50Ω 2μV c.w. gives 1W audio with +20dB sig./noise ratio |
| sideband | either upper or lower or optional selection switch |
| audio output | > 1W (12V), > 2W (24V) |
| audio response selectivity | 300Hz to 2.6kHz (6dB) other sideband > 50dB, other signals > 60dB |
| a.g.c. transmitter | 2μV to 100mV, 4dB |
| audio gain | 10dB change for 30dB input variation, peak clipping to prevent sideband splash |
| carrier suppression | better than 30dB |
| intermodulation out-of-band radiation | for two tones, < 30dB 100mW for 100W output |

Murphy Telecommunications Systems Ltd,
North Bradley House, North Bradley,
Trowbridge, Wilts.

WW518 for further details

Weather chart recorder

The highlight of Muirhead's display was a new solid state weather chart recorder, the K-649-TR4. The recorder operates automatically at the standard speeds of 60, 90, 120 rev/min d.s.b. and 240 rev/min v.s.b. A composite a.m./f.m.

recorder is available, incorporating switched selection from one mode to the other. Improved Muirhead electrosensitive paper provides a durable half-tone copy which is a dyeline master; each roll of paper being sufficient for approximately fifty 45.4cm × 56cm charts. When operating from a Muirhead transmitter, the reproduced chart is the same size as the original. Standard test facilities are built in for routine performance checks. Dimensions: 58 × 74.3 × 35.6cm, weight 68kg. Muirhead Ltd, Beckenham, Kent.

WW513 for further details

V.H.F. aerial distribution amplifier

Designed to operate in the band 146 to 148MHz (or 154 to 156MHz) an aerial distribution amplifier from Airtech provides eight 50Ω outlets. When tuned to 155MHz a signal at 148MHz is >50dB down. Signals in the bands 40 to 70, 80 to 84, and 97.1 to 102.1MHz are attenuated 50dB relative to the in-band response. The

noise factor is < 5dB, the input impedance is 50Ω and the input circuit is conductive to d.c. to discharge voltages developed across the aerial during atmospheric disturbances. Airtech Ltd, Haddenham, Aylesbury, Bucks.

WW511 for further details

Marine aerial rotator

J. Beam Engineering exhibited a heavy duty aerial rotator which has been designed for deck mounting and which will survive the harsh marine environment. Weather-proofing is achieved using neoprene cork gaskets which are satisfactory between -15 and 40°C. Drive power is derived from two 240V, 50Hz squirrel cage motors. The major speed reduction is achieved using bronze worm and gear wheels to a stainless steel final drive shaft. Rotation is 360 deg. at 10 deg/s. J. Beam Engineering Ltd, Rothersthorpe Crescent, Northampton.

WW504 for further details

Colour video display system

Moore Reed showed the VT109 colour video display system consisting of a single keyboard and electronics package used in conjunction with a standard 625 line TV monitor. The VT109 requires no special interface and is designed to accept serial or parallel inputs from any one of the many computers in common industrial use. The use of colour adds considerable clarity to complex combinations of alpha-numeric and graphic information. Displays which would otherwise appear cluttered and even unrecognizable in monochrome can be transformed by the addition of colour. Any four of seven colours are supplied as standard. Additional colours are available if required.

In addition to offering colour alpha- numerics the VT109 incorporates sets of

graphic symbols. These allow the user to display complex block and flow diagrams. They include basic symbols such as vertical lines, horizontal lines and corners. In addition complete sets of symbols tailored to individual industries can be supplied.

The basis of the display is a 15,360 bit random access memory. The contents of the memory are circulated through a character generator to produce the video display. The rest of the electronics supplies the necessary timing and controls for clocking serial and parallel information into and out of the memory. The circuits are divided into groups according to the different functions which they cover. Moore Reed & Co. Ltd, Walworth Industrial Estate, Andover, Hants.

WW501 for further details

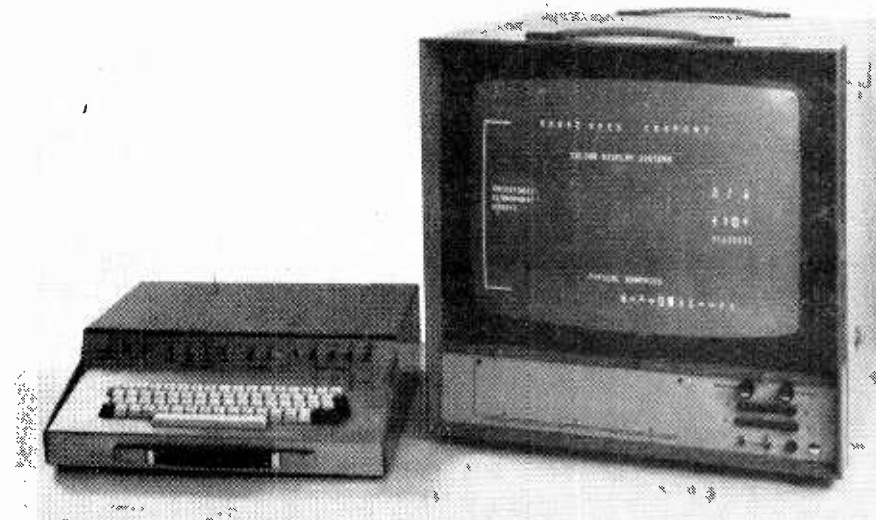

V.H.F. scanning receiver

A receiver designed to fill the need of all air mobile band users for a compact multi-channel monitor for use on and around airports was introduced by Park Air Electronics. The "Double S Line Monitor" (model 16W/SS) uses a channel scanning technique which examines up to eight crystal controlled channels. A light emitting diode display identifies the channel being scanned. On receipt of a wanted on channel signal the scanning action is inhibited for the duration of the signal and its reply, and then the scanning action is re-commenced. Channels not wanted by the operator may be switched out or the channel scanning may be undertaken manually if desired.

The 16W/SS operates in the 118MHz to 136MHz air mobile band with either 100kHz or 50kHz channels. Replacement crystals may be fitted easily by unskilled personnel on site, only one adjustment being necessary.

| | |
|----------------------------------|---|
| frequency range | 118MHz to 136MHz a.m. A3 modulation |
| sensitivity | 2 μ V 30% modulated at 1kHz will produce 500mW audio output |
| signal plus noise to noise ratio | with a 2 μ V signal 30% modulated at 1kHz not less than 12dB |
| oscillator stability | better than 30 p.p.m. from -10°C to 55°C |
| a.g.c. action | a signal that increases from 2 μ V to 10mV will not produce a change of output of more than 3dB |
| a.f. distortion | less than 5% at 500mW output |
| channel scanning time | 400ms or approximately 50ms per channel |
| mute lifting level | 1 μ V up to 3 μ V set by front panel control |
| r.f. input impedance | 50 Ω b.n.c. socket |
| a.f. output impedance | 15 Ω minimum |
| audio output | 500mW |
| size: | 265mm x 90mm x 250mm |

price: £110 excluding crystals

Park Air Electronics, Ryhall Road, Stamford, Lincs.

WW515 for further details

Programmable modular signal generator

A signal generator from Farnell uses a series of plug-in modules so that a customer need buy only the facilities he requires and can extend the instrument at a later date to meet changing requirements.

Four oscillator modules are available. These are the MSG1, 400kHz to 10MHz in five ranges; the MSG2, 10 to 100MHz in five ranges; MSG3, 70 to 470MHz in four ranges; and the MSG4, 400MHz to 1.5GHz in three ranges. Taking the MSG2 as an example. This will provide outputs

in the following five ranges: 9 to 17, 14 to 27, 21 to 44, 33 to 68 and 49 to 103MHz. The output can be adjusted between 1 μ V and 1V and the output impedance is 50 Ω . The level is flat (within 0.5dB) over the whole range and the harmonic content does not exceed -30dB. Frequency accuracy is $\pm 2\%$ and stability exceeds 50 p.p.m. in 10min after a one hour warm up period. The oscillator can be remotely controlled by earthing rear panel connections for range changing and applying a voltage between -5 and +25V for frequency selection.

The programmable attenuator module (MSA) will operate over the frequency range d.c. to 1.5GHz and has a power rating of 0.5W. The module will provide attenuation ratios of 0 to 122dB in 1dB increments the switched steps being: 1, 2, 3, 6, 10, 20, 20, 20 and 20dB, the overall accuracy being ± 1 dB. Leakage is such that the attenuator can be used with equipment with less than 1 μ V sensitivity.

A calibrator module (MSC) is available which can be used to check spot frequencies to assess dial accuracy and to provide marker pips when used with the sweep module mentioned below. The calibrator incorporates a frequency coincidence indicator lamp to simplify operation and provides outputs of 1, 10 and 100MHz (harmonics up to 1.5GHz). Frequency accuracy is 0.005%.

The modulator module (MSM) is used with the oscillator module to provide a.m. or f.m. signals from an internal or external l.f. oscillator. The internal l.f. oscillator will operate at 400Hz or 1kHz $\pm 5\%$ or can be varied between 80Hz and 6kHz (uncalibrated). The level of modulation can be varied between 0 and 70% (a.m.) or 0 to 100kHz peak deviation f.m. The modulation linearity is <3% at 30% modulation (a.m.) or 1.5% at maximum deviation (f.m.).

Another modular adjunct for the basic oscillator is the sweeper (MSS) which has two sweep speed ranges: 34 to 165 sweeps/s (*scope), 10-60 sweeps/s (XY plotter). The centre frequency is variable over the complete range of the oscillator module band selected. The X output is variable from 0 to 28V peak-to-peak centred on 10V and the output from the Y detector (which has a range from 100kHz to 1.5GHz) is adjustable from 0V to 25V.

A power supply module (MPS) completes the ensemble. Farnell Instruments Ltd, Sandbeck Way, Wetherby, Yorks. LS22 4DH.

WW514 for further details

1Hz to 10MHz signal generator

New items shown by Green Electronic and Communication Equipment Ltd included a true r.m.s. terminating wattmeter, a 60MHz frequency meter/counter, an off-air 1 and 10MHz output standard receiver (phase locked to Droitwich), and a 1Hz to 10MHz (in 7 ranges) signal generator. This

latter item has an internal standard with a stability of 3 parts in 10⁹/day or 1 part in 10⁶/year. Accuracy is 1 part in 10⁷. The setting resolution of the generator is between 1 part in 10⁴ and 1 part in 10⁵ with a frequency lock time of <3s (1s typical). Both square and sine outputs are available throughout the whole of the frequency range and, in addition, fixed frequency outputs are available at 1, 5, 10 and 100kHz, and 10, 50, 100 and 500Hz. The spurious content of the output signal is as follows (dB below signal level): background noise >65dB, hum 45dB, harmonics >35dB (50Hz to 1MHz) and >30dB (1 to 10MHz). The generator has all the other facilities one would expect from a good quality instrument. Green Electronic & Communication Equipment Ltd, 5-15 Thorold Road, London N22 4YE.

WW509 for further details

406 to 470MHz aerial

The model 360 aerial from Airtech consists of a parabolic cylinder reflector with a two-element Yagi back-firing radiator. The system was developed to produce a higher gain than corner reflectors of comparable cost without going to the expense of a full paraboloid.

| | |
|---------------------|---|
| gain | 15dB over half-wave dipole |
| impedance (nominal) | 50 Ω |
| power rating | 250W |
| polarization | horizontal or vertical |
| weather rating | 85 m.p.h. wind with 12.7mm coating of ice |

Airtech Ltd, Haddenham, Aylesbury, Bucks.

WW505 for further details

Mobile facsimile system

Muirhead displayed (and read a paper on) their new mobile facsimile system which is currently undergoing trials by the Home Office. The equipment allows pictures and speech to be received by a standard mobile receiver (say in a car); the advantages to such organizations as the police are obvious. There are three basic units in the mobile facsimile set-up: a base station transmitter which is a development of the Muirhead K400 document transmitter, a small recording unit in which the picture is printed on Mufax electrolytic paper, and an electronics unit which would normally be fitted in the boot of the car. Several different transmission systems are available. One is to frequency modulate the facsimile information on to a 4.25kHz sub-carrier with a maximum deviation of ± 250 Hz. With a paper feed of 100mm/min the sidebands extend to ± 1.25 kHz and the entire facsimile signal occupies a band from 3.5

to 5.5kHz. Alternative methods, although giving slower paper speeds, use less bandwidth. Muirhead Ltd, Beckenham, Kent. **WW512 for further details**

A.M., F.M., V.H.F. signal generator

The type 1525 is a v.h.f. signal generator from Dymar intended for use with v.h.f. radiotelephone equipment.

| | |
|-------------------------------------|--|
| frequency range | 100kHz to 44MHz, 44 to 92MHz, 88 to 184 MHz |
| calibration accuracy | 0.01% at crystal check points |
| frequency readout | drum scale with an effective length in excess of 50cm. |
| fine tuning | electronic tuning with approximately ± 1 kHz range |
| frequency stability | at constant temperature after 1 hour's warm-up, 0.001% over a period of 10 minutes |
| incremental frequency | calibrated frequency shift of ± 25 kHz, calibration accuracy 10% |
| external shift | ± 6 V d.c. relative to a potential of -6 V d.c. will shift frequency approximately ± 25 kHz |
| modulation amplitude modulation | continuously variable 0-50% (up to 90% depth uncalibrated) |
| setting accuracy | 5% of f.s.d. |
| frequency range envelope distortion | 30Hz to 10kHz better than 3% at 1kHz and 30% depth of modulation |
| frequency modulation | continuously variable. 3 ranges giving full scale deviations of 1.5kHz, 5kHz and 15kHz |
| setting accuracy | 10% of f.s.d. |
| frequency range distortion | 30Hz to 30kHz better than 3% at 5kHz deviation |
| r.f. output level | 100mV to 0.1 μ V e.m.f. or p.d. into 50 Ω adjustable in steps of 2dB. Interpolation from -1 dB to $+1$ dB continuously on meter |
| accuracy | ± 1 dB at 1 μ V and above |
| output impedance | 50 Ω with a v.s.w.r. of 1.25:1 |
| leakage | less than 1 μ V |
| <i>auxiliary outputs</i> | |
| a.f. oscillator | 30Hz to 30kHz in 3 ranges |
| output voltage | continuously variable 0-1.5V into 600 Ω measured on meter |
| i.f. oscillator | 10.7MHz crystal controlled |

Dymar Electronics Ltd, Colonial Way, Radlett Road, Watford, Herts WD2 4LA. **WW510 for further details**

Automatic call makers

The Post Office showed three automatic call makers suitable for domestic or office use. All three consisted of units which are connected to the existing telephone. The first used plastic cards which could be easily punched by the user and labelled with a person's name. These are housed in an alphabetically indexed file (supplied) until required. To make a call one simply places a card into the add-on unit and the number is automatically dialled. The length of any one number is limited to 16 digits.

The second unit will store up to 400 18-digit numbers on magnetic tape. The tape, which is 76mm wide, has writing surfaces for writing the names of persons whose telephone numbers are stored. As the tape is moved (by a motor) a cursor traverses an alphabetical index. To make a call a rocker switch is pressed which causes the tape to move until the required person's name appears between a pair of guidelines on the front window of the unit (the final positioning can be done by hand using a large plastics knurled knob). The call is then made by pressing a button once. The numbers are recorded initially using an auxiliary telephone dial which plugs into the unit. The tape is moved to the required position (as indicated by the index), the number is dialled and the person's name is written in soft pencil on the tape. The number will then have been recorded. Numbers can be stored, erased or altered by the user at will.

The third unit has 32 push-buttons and each button will dial one number.

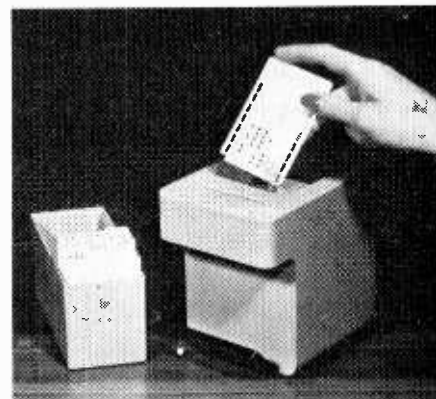

Although in production the Post Office still have only limited supplies and prospective customers may have to wait some time for delivery. The least expensive of the units cost £3 a quarter to rent and there is an initial installation charge.

Motor tuned h.f. aerial

A motor tuned h.f. aerial for mobile use is available from Bantex. The main features of the aerial are as follows: continuously tunable 2 to 15MHz (12 to 25MHz lower section only); near centre-loaded for high efficiency; power rating 100W p.e.p.; nominal impedance 75 Ω ; control supply 12V d.c.; standing wave ratio 1.5:1 over 90% of frequency range; nominal feed impedance 75 Ω . Bantex Ltd, Abbey Road, Park Royal, London N.W.10. **WW507 for further details**

1.54 to 8.2GHz sources

The ML18021 to ML18091 are solid-state microwave sources providing outputs at any frequency from 1.54 to 8.2GHz. A fundamental cavity oscillator, tuned to approximately 1GHz, is phase-locked to an internal quartz crystal reference and provides the drive power for a frequency multiplier. The fundamental frequency and the multiplication ratio are chosen such that the output of the source is at the desired frequency. The available output power lies in the range 20 to 110mW, depending upon the output frequency required. Frequency stability is 25 p.p.m. on the

standard model but stabilities as high as 1 p.p.m. can be provided. Microwave Associates Ltd, Luton, Beds. **WW516 for further details**

Microwave link analyser

The Hewlett-Packard microwave link analyser (exhibited) is a combined baseband (b.b.) and intermediate frequency analyser permitting rapid tuning and equalization of satellite and terrestrial radio relay links. The instrument allows the various forms of distortion occurring in a link to be identified, measured and localized to b.b. and i.f. devices and b.b./i.f. combination devices (e.g. modulators and/or demodulators). From these measurements, it is also possible to deduce the radio frequency performance of the link. Inclusion of high frequency b.b. test signals, corresponding to the upper b.b. frequency of the link, permits the detection of amplitude to phase modulation conversion effects. Optimization of the link differential gain and phase performance using these frequencies will achieve closer agreement with optimization performed by using white noise loading tests.

Independent operation of the transmit

and receive portions of the equipment allow between station (multi-hop) measurements as well as in-station measurement. Measurements made at the distant end of a between station test can be observed at the local end by a 'slave' facility involving two microwave link analyzers and the return path of the link. The measurement slaved back is immune from the characteristics of the return path.

Measurements are made throughout the i.f. swept spectrum of 45 to 95MHz (including demodulation of b.b. frequencies up to 5.6MHz) and at seven discrete b.b. frequencies within the range 83.3kHz to 8.2MHz. External modulation facilities on the equipment allow compatibility with a wide range of test gear. Hewlett-Packard Ltd, 224 Bath Road, Slough, Bucks.

WW508 for further details

Mobile transmitter module

Solid-state modules that will simplify the design and manufacture of u.h.f. power amplifiers for mobile communications equipment were shown by Mullard. Development types 380BGY and 381BGY contain amplifiers with a bandwidth extending from 380 to 512MHz. One or more modules, depending on the power required, can form a complete amplifier. The modules have input and output impedances of 50Ω and can be coupled together. They have been designed to minimize the effects of changes in ambient temperature and supply voltage usually experienced by mobile equipment, and can withstand the load mismatches occurring in mobile radio systems. They are robust devices designed to withstand the rough treatment that mobile equipment sometimes meets in the field.

380BGY 381BGY

| | | |
|--------------------------|------|--------|
| input power | 0.05 | 2.5 W |
| output power | 2.5 | 7.0 W |
| normal operating voltage | 13.8 | 13.8 V |

Mullard Ltd, Mullard House, Torrington Place, London WC1E 7HD.

WW502 for further details

Marine v.h.f. radiotelephone

Among the many new products announced by Dymar was the marine radiotelephone type 824 designed for the light marine and pleasure boat market. The equipment meets the relevant British Ministry of Posts and Telecommunications Specifications.

The 824 is housed in a robust aluminium case and an interesting feature is the automatically tuned receiver front end, which permits the set to work in either simplex or semi-duplex mode. Particular attention has been paid to the maintenance accessibility aspect of the equipment, for example the bottom chassis of the set is hinged, permitting easy access to all components. Without going into all the relevant details (a leaflet can be obtained by using the

reader reply card) the equipment can be summed up as follows: r.f. power output 20W, channels 1-10, simplex and semi-duplex, solid state with integrated circuits, small dimensions, easy to install, and minimal power consumption. Dymar Electronics Ltd, Colonial Way, Radlett Road, Watford, Herts WD2 4LA.

WW506 for further details

Long filament lamps

A range of long horizontal filament (Festoon) lamps were introduced by H. F. Collison-Goodwell Ltd which produce a straight horizontal line of light from 30 to 80mm long. A very small spring is used at each end of the filament to hold the filament in tension to maintain the straight line.

| | |
|-----------------|--|
| voltage range | 1 to 60 |
| current range | 7mA to 1A |
| sizes available | T $\frac{1}{2}$ (2mm) to T3 (10mm) |
| terminations | wire, miniature flange, bi-pin, screw, B.A., clip and slide/wedge telephone. |

H. F. Collison-Goodwell Ltd, Coleshill, Birmingham B46 3BL.

WW503 for further details

P.I.N. diodes

A range of p.i.n. diodes has been introduced by Microwave Associates which features high breakdown voltage and low leakage currents. The range, types 4602 to 4605, has breakdown voltages (at $I_R = 10\mu A$) of 90 to 600V. Junction capacitances at 1MHz vary from 0.15 to 0.45pF and the minority carrier lifetime is 80ns for the 4602 to 2000ns for the 4605. The diodes are intended for r.f. switching, limiting, phase shifting, duplexing, modulation and pulse forming. They can also be useful in various attenuator applications. Microwave Associates Ltd, Luton, Beds.

WW520 for further details

Audio selective level measuring set

Wayne Kerr exhibited a new level measuring set, the model 36A, which covers the frequency band 30Hz to 120kHz in four switched ranges (30Hz to 1kHz, 1 to 5kHz, 5 to 20kHz and 20 to 120kHz). There is a two-position switch which selects a bandwidth of either 18Hz or 1kHz. The input impedance selector has a six position switch which allows connection to a 75, 140 or 600 Ω line with or without an internal terminating resistor. An input level four-position switch is calibrated from -20 to +20dB. Measurements can be made from -95 to +25dBm with an accuracy of ±0.5dB. Wayne Kerr Company Ltd, Tolworth Close, Tolworth, Surbiton, Surrey KT6 7ER.

WW521 for further details

Books Received

Integrated Circuit Pocket Book by R. G. Hibbert is a follow-up to an earlier work, "Transistor Pocket Book" by the same author and continues the story of solid-state electronics into integrated circuits. The nature of the book is general and practical. After an introduction to the basic principles behind device integration (small size, price, performance, reliability, etc.), two types of technology involved in manufacture are considered (silicon planar and bipolar). Chapters describe digital, linear, m.s.i. and l.s.i. and the uses of the different types of integrated circuits including practical examples of application. Pp. 274. Price £2.50. The Butterworth Group, 88 Kingsway, London WC2B 6AB.

Microwave Power Measurement by J. A. Lane, D.Sc., F.I.E.E., makes special reference to methods for high measurement accuracy. The widespread application of microwaves for military and civilian use — especially space communication — has necessitated the development of a wide range of microwave measurement methods, of which power measurement is the most important. The academic level of the techniques presented is postgraduate and the approach is a practical one. Only the essentials of theoretical work are included. In addition to waveguide techniques, a review of the methods used in coaxial lines at frequencies above about 1GHz is given, as many microwave systems now include both waveguide and coaxial-line components. Pp. 72. Price £2.75. Peter Peregrinus Ltd, 2 Savoy Hill, London WC2R 0BP.

Electret Devices for Air Pollution Control, edited by Thomas Kallard, relates to the various methods of producing electrets and, more particularly, to their applications for air pollution control. The electret, an electrical analogue of a permanent magnet, is a permanently polarized dielectric that can be used as the source of an electrostatic field. There has been research and development in many countries to find improved electret-forming materials and to develop their applications as transducers, electrometers, power converters, generators, space propulsion systems, electrophotographic and data storage means. Electrets can be used as filters in dust suction equipment, fans, motor exhausts, cigarette filters and air filters. Twenty-one patents are fully described and illustrated in this book, and these present the development in chronological order of the electret between 1929 and 1972. Pp. 126. Price \$9.95. Optosonic Press, Box 883, Ansonia Station, New York, N.Y. 10023, U.S.A.

The Complete Linear Book, published by Fairchild Semiconductor Ltd, is a data catalogue and reference manual, containing complete information on the Fairchild range of linear integrated circuits. It is arranged to permit quick reference to information such as specification data, characteristics and performance graphs, connection diagrams, block schematics and ordering information. Chapter subjects include application reports, recent linear circuitry, planned linear products and dice. Applications, together with complete circuitry, are included for many devices. Pp. 696. Price £1.00. Fairchild Semiconductor Ltd, Kingmaker House, Station Road, New Barnet, Herts.

Displaying Phasor Diagrams

by A. R. Carruthers*, B.Sc., and J. H. Evans* Dip Tech. (Eng.)

An electronic system that gives a realistic visual demonstration of complexor (phasor) diagrams on the screen of a cathode ray tube is described. One complexor is used as the reference and shown as a horizontal straight line from the centre of the display screen, while the other complexors have their extremity marked by a dot. This representation permits the display of complexor loci as test-circuit parameters are altered. Although the circuits shown were designed for use on 50-Hz a.c. systems, they may be modified fairly readily for use at other frequencies.

The ability to present the basic theory of electrical engineering in a clear and concise manner is enhanced by the use of good visual aids. These aids are the keys to motivating interest, ensuring greater assimilation or imparting more information.

Complexor, phasor or vector diagrams provide an elegant representation of circuit or system behaviour under sinusoidal excitation and are normally introduced at an early stage to students of alternating current theory. A complexor diagram is a diagram containing any non-vector quantity that can be expressed as a complex number. A phasor diagram is a particular kind of complexor diagram that contains only phasors, which are complexors—such as current and potential difference—that are derived from time-varying sinusoidal quantities.

Although these diagrams form a powerful visual aid in themselves, a more convincing exposition of their usefulness and limitations is provided if they are generated directly from real physical circuits or systems.¹ The electronic system used to generate complexors has many uses other than as a teaching aid; it is also a versatile laboratory measuring instrument which can provide, for example, a rapid, direct indication of gain and phase shift.

System philosophy

Fig. 1 shows the system connections for displaying a reference and *n* other complexors, the unused inputs being connected to the datum line. Normally, a calibrated attenuator is required for each input as the complexor generator is designed to give an adequate c.r.t. display with input amplitudes up to only a few hundred millivolts. This facilitates the display of current complexors, without significantly changing the performance of the system under test, by using the potential difference across small series resistors.

The operation of the complexor generator is based on the following principles.

To ensure that amplitude and phase comparisons between alternating quantities are meaningful, the waveforms in the system under test must be sinusoidal functions of time. Thus, the complexor generator input signals will be of the form

$$v_R(t) = V_R \sin \omega t$$

$$v_k(t) = V_k \sin(\omega t + \theta_k)$$

where $v_R(t)$ and $v_k(t)$ are the signals applied to the reference and *k*th complexor inputs respectively, the latter having an amplitude V_k and a phase angle θ_k with respect to $v_R(t)$. The choice of the reference quantity is determined by the user and all other quantities chosen as complexors are automatically displayed with respect to the reference which is plotted as an horizontal line along the positive axis of the complex plane on the screen.

As all input signals have the same periodic time $T = 2\pi/\omega$ sec, then at time $t = 0$, the instantaneous values of the input signals are

$$v_R(0) = 0$$

$$v_k(0) = V_k \sin \theta_k \tag{1}$$

and represent the quadrature components of the displayed complexors. At $t = T/4$,

$$v_R(T/4) = V_R$$

$$v_k(T/4) = V_k \cos \theta_k \tag{2}$$

and represent the in-phase or real-axis components of the displayed complexors.

To realize the complexor display, equations 1 and 2 are electronically processed so that the reference signal is applied to the *x*-plates of the c.r.t. during its first quarter period $0 < t < T/4$. The waveforms of the remaining signals are sampled at time $t = 0$ and $t = T/4$ and the sampled information retained in sample-and-hold circuits until required for application to the deflection plates of the c.r.t. within the remaining time interval $T/4 < t < T$.

Potential $v_R(t)$ applied to the c.r.t. *x*-plates for $0 < t < T/4$ will produce a horizontal straight line of length l_R cm on the screen, and is proportional to its amplitude V_R . The stored component values $v_k(0)$ and $v_k(T/4)$, are applied to the *y* and *x* plates respectively, for a small interval of time δ sec, during $T/4 < t < T$ thus producing an illuminated spot for each complexor. The interval $T/4 < t < T$ is composed of a succession of time slots of width δ , each reserved for a single complexor to prevent interference between the components of a complete display. To provide a continuous display, these operations are repeated once per cycle of the reference signal and the display of all complexors per cycle must be completed within the time $T/4 < t < T$. The individual-complexor display time δ is determined by the maximum number

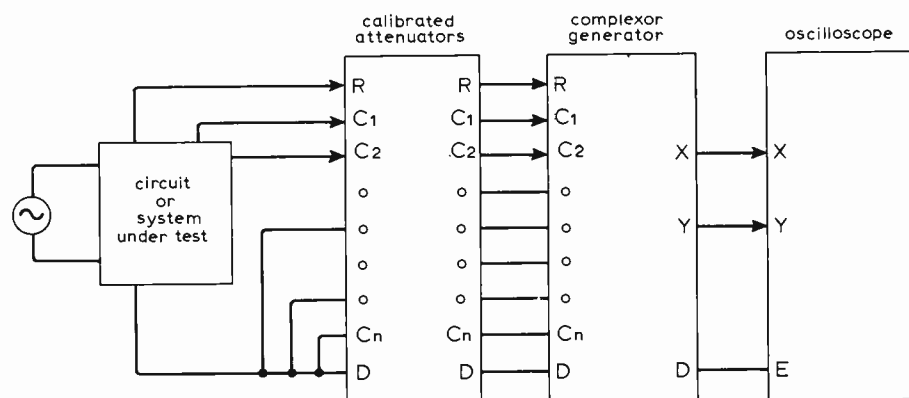

Fig. 1. System connections for displaying complexors, one acting as a reference.

* Paisley College of Technology.

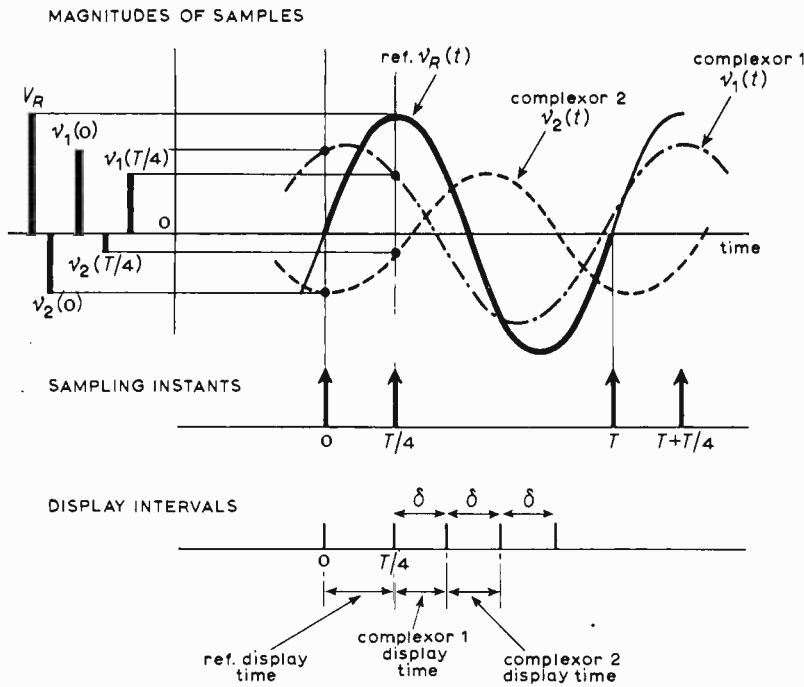

Fig. 2. Relationship between sampling and display times and the display.

of complexors to be generated by the apparatus.

As quadrature and in-phase components of a signal are displayed simultaneously, the resulting illuminated dot on the c.r.t. screen will be displaced from the undeflected point by an amount l_k cm at an angle θ_k to the horizontal reference complexor. If the x - and y -sensitivities of the tube are assumed equal and to have a value S cm/V then

$$l_k = Sv_k(T/4) + jSv_k(0) \text{ cm}$$

Thus from equations 1 and 2

$$l_k = SV_k(\cos\theta_k + j\sin\theta_k) \text{ cm}$$

or $l_k = SV_k \exp(j\theta_k) \text{ cm}$

Representative waveforms showing the relationship between the sampling and display times and the form of the c.r.t. display are illustrated in Fig. 2

System description

A block diagram of the complete generator system for the reference and two other complexor channels is shown in Fig. 3.

The sinusoidal output signal $v_R(t)$, from the reference bandpass filter traverses two control paths, one containing a -90° phase shifting circuit to ensure a voltage in quadrature lag with $v_R(t)$. The quadrature and reference voltages are fed through identical square-up circuits to produce quadrature square waves in which transitions are locked to the zero points of the sinusoidal waveforms. Differentiation of the square waves generates the trigger and reset pulses for a master bistable circuit, which in turn provides a square pulse of width $T/4$.

This pulse performs two functions. It opens an analogue gate for the reference waveform during the interval $0 < t < T/4$ to display the horizontal reference com-

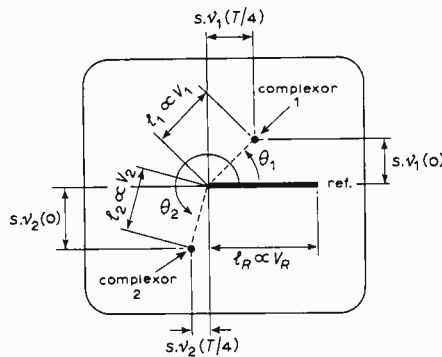

plexor, and its leading and trailing edges initiate the operation of a sequential chain of monostable circuits. These generate sampling pulses at times $t = 0$ and $t = T/4$, and gating pulses of width δ , to initiate the display during time $T/4 < t < T$.

Each remaining complexor channel contains a filter that is identical to the one in the reference channel. The output of each filter is connected to a pair of sample-and-hold circuits which store the quantities $v_k(0)$ and $v_k(T/4)$. The stored information is transmitted to the mixer and output amplifiers, and subsequently to the x and y plates of the c.r.t., via a pair of analogue gates which are opened by the appropriate monostable to display pulses of width δ . (The mixer and output amplifiers provide facilities for adjusting the gain of the system and for removing any zero-shift in the display due to the presence of d.c. offsets.)

Fig. 4 shows the position, with respect to time, of all the pulses generated to perform the sampling and gating functions. They are defined as follows:

- P_R opens the analogue gate to display the reference complexor for $T/4$ sec.
- P_0 is the $t = 0$ sampling pulse used to obtain the value of $v_k(0)$ for each of the other complexors.
- $P_{T/4}$ is the $t = T/4$ sampling pulse used to obtain the value of $v_k(T/4)$.

- A_1 and A_2 are the display pulses, of width δ , used to open the analogue gates for the x and y -components of complexors 1 and 2 respectively.

- P_W is the last pulse in the sequence and is used to remove all information from the memory of the sample-and-hold circuits. This allows fresh information to be stored and displayed during the subsequent cycle. The time allocated to this clearing pulse is W sec so the width of the display pulses δ is

$$\delta = \frac{3T/4}{(n-1)} - \frac{(W+a)}{(n-1)} \text{ sec}$$

where n is the maximum number of complexors including the reference, and a is the width of the $P_{T/4}$ sampling pulse. If the number of complexors to be displayed is small, the usual case, then the clearing pulse width W can be made much greater than the sampling pulse width a , and

$$\delta = \frac{(3T/4) - W}{(n-1)} \text{ sec}$$

Circuit details

The complete circuit for a 50-Hz, fixed-frequency system is shown on pages 384-5.

Each input signal to the complexor generator is fed to a bandpass filter through a high input impedance follower. The follower provides good isolation between the input attenuator and the filter, which has a low input impedance at its resonant frequency. The filters are of the Wien bridge type,² this configuration being chosen for its flexibility as the resonant frequency can be varied over a wide range without significantly changing insertion gain by simply ganging either R_1 and R_2 or C_1 and C_2 . In addition, the insertion gain and filter Q -factor are readily varied by changing the ratio Z_3/Z_4 . Such facilities as these allow the filters to be easily modified for applications requiring the display of loci of circuits having a variable input frequency.

The filters have a theoretical voltage transfer function

$$T_1 = -\frac{(1-\lambda)}{(\rho-\lambda)} \quad (3)$$

where $\rho = Z_1/Z_2$ and $\lambda = Z_3/Z_4$. At the resonant frequency, equation 3 becomes

$$|T_1(\omega_0)| = \frac{1-\lambda}{2-\lambda}$$

when $\omega_0 = 1/CR_1$.

The square-up requirements for the reference channel are met by open-loop operational amplifiers which provide a mark-to-space ratio that is sufficiently close to the ideal value of unity.

The -90° phase shifter, needed in one of the square-up paths, is a simple design suitable for the fixed-frequency system. Its ideal voltage transfer function is

$$T_2 = \frac{(1-j\omega C_5 R_5)^2}{1-(j\omega C_5 R_5)^2} = 1/-2\phi$$

where $\phi = \tan^{-1} \omega C_5 R_5 = 45^\circ$ at the resonant frequency. If frequency is one of the input parameters, a wideband -90° phase shift network would be more convenient.³

The master bistable and monostable pulse-generating chain are conventional transistor circuits but there is no fundamental restriction to using integrated circuitry. Pulse widths are under the control of the designer and are chosen to suit the expected application of the system, the number of complexors to be displayed or the accuracy desired. Timing of the sampling pulses P_0 and $P_{T/4}$ critically determines the accuracy of the displayed complexor diagrams. Clearing pulse P_W must have a width that ensures that circuit parameter variations due to temperature changes, component tolerance and ageing, etc., do not cause the next P_0 sampling pulse to overlap the clearing time of P_W . To display frequency-dependent loci the pulse-generating chain would need modification, but this would be eased if a reference and one locus only were displayed.

The sample-and-hold circuits are all

identical; with the output signals from the bandpass filters charging a low-leakage capacitor C_6 when the appropriate monostable supplies a P_0 or $P_{T/4}$ sampling pulse to open the series j.f.e.t. gate. A follower isolates C_6 to ensure retention of its charge until removed by the parallel j.f.e.t. switched on by the clearing pulse P_W on its gate. Voltages of either polarity can be stored to allow a four-quadrant complexor display.

Series-shunt connected analogue gates open under the control of a display pulse A_k . This gating arrangement provides inherent suppression of the transient spikes arising from breakthrough of the gate pulses. These circuits employ j.f.e.t.s in preference to m.o.s.f.e.t.s as the former require only relatively low-amplitude gate pulses.

The mixer amplifiers are of the summing operational amplifier type with the input paths to the summing junction containing a

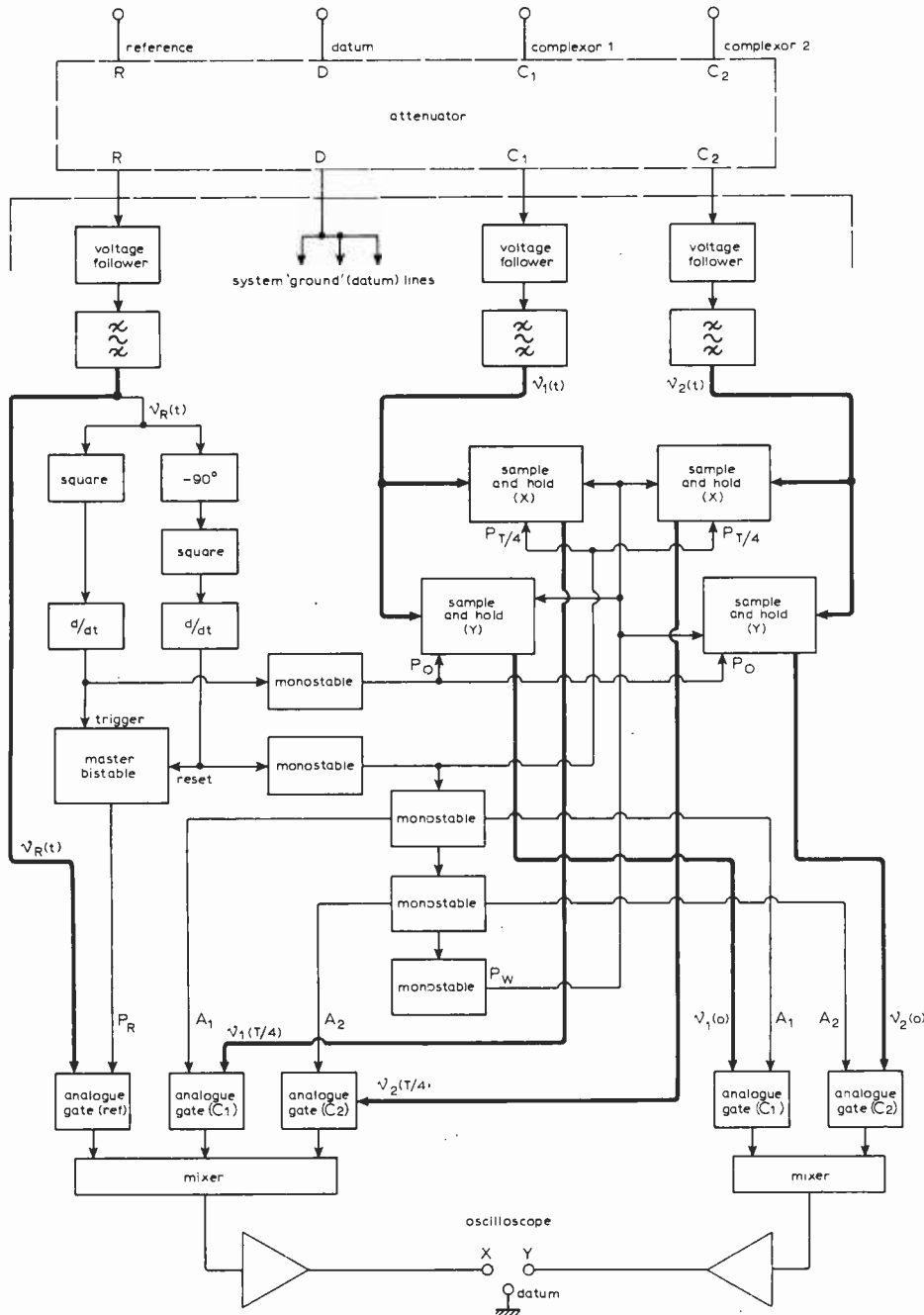

Fig. 3. Block diagram of generator system for a reference and two other complexor signals.

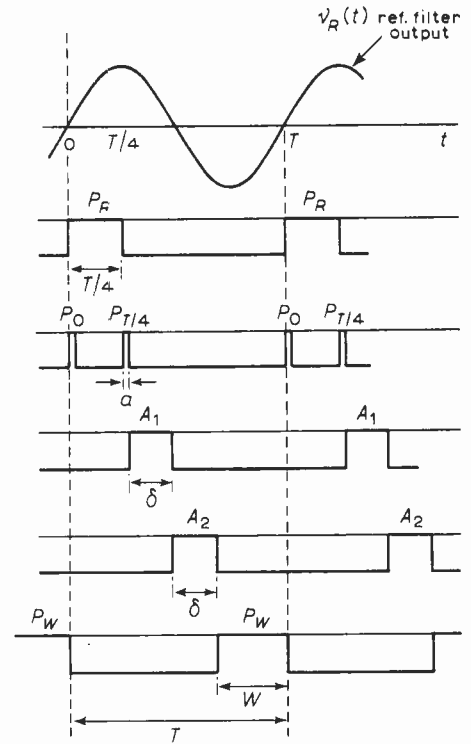

Fig. 4. Position of pulses generated for sampling and gating.

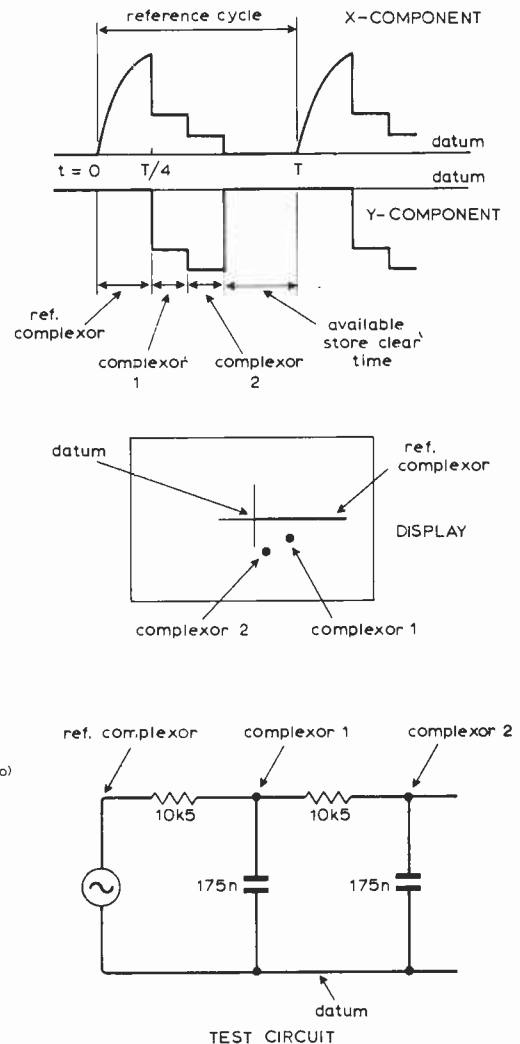

Fig. 5. Typical waveforms from the output amplifiers.

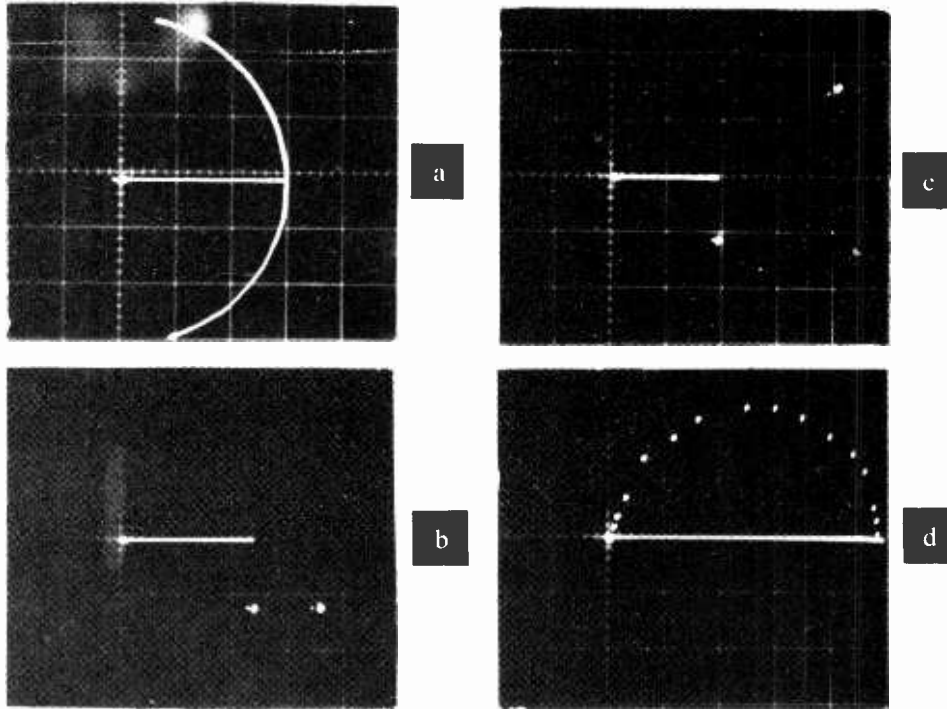
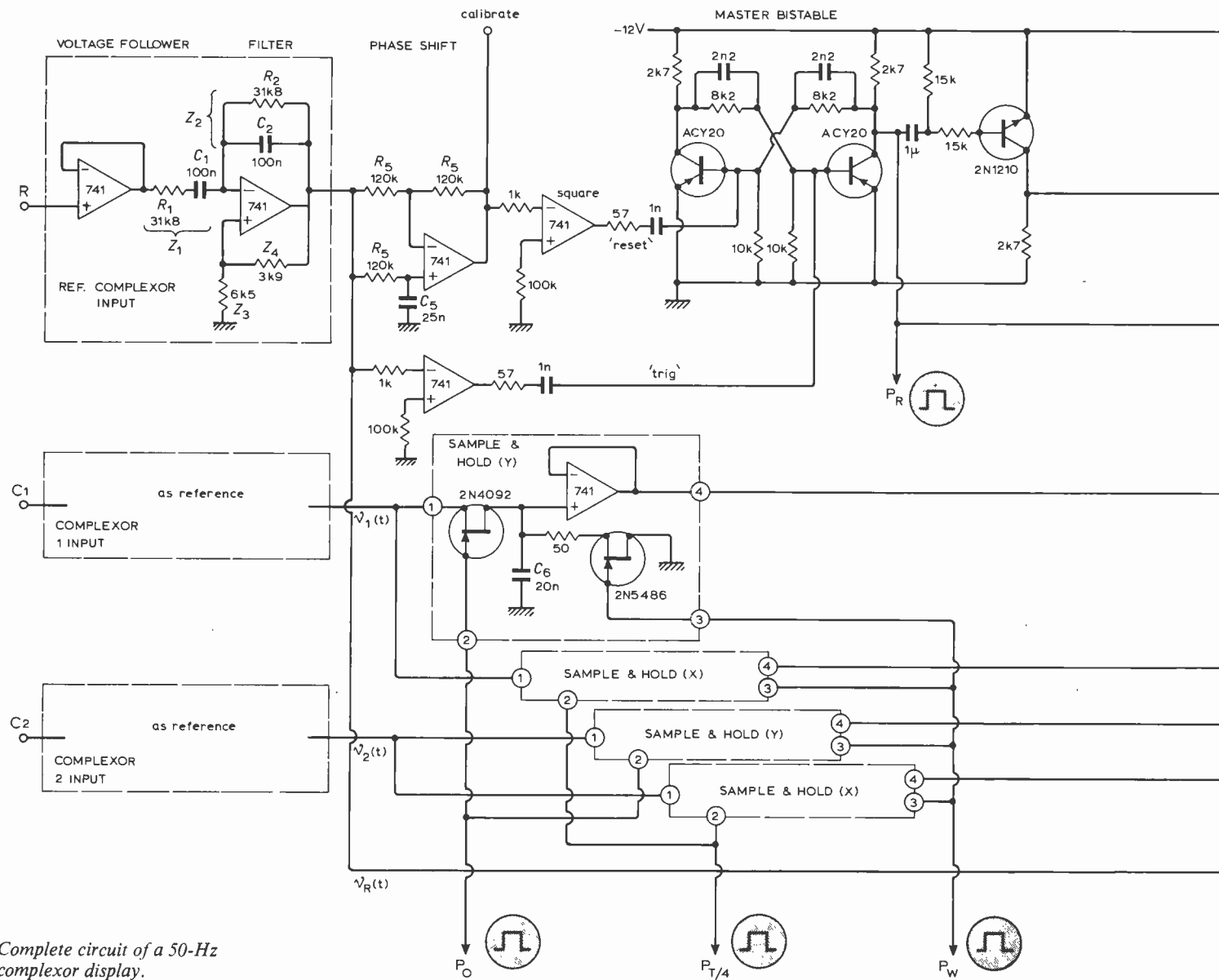

Fig. 6(a). Demonstrating frequency modulation using the method of Fig. 7(a). Horizontal line represents unmodulated carrier and arc is the locus of phase angle as frequency varies with the sinusoidal modulation. (b) Display obtained using network in Fig. 7(b) and (c). (c) Replacing R_2 in Fig. 7(b) with an iron-cored choke results in this display. (d) Locus of current referred to supply voltage in series RC network as C is varied from 100pF upward.



Complete circuit of a 50-Hz complexor display.

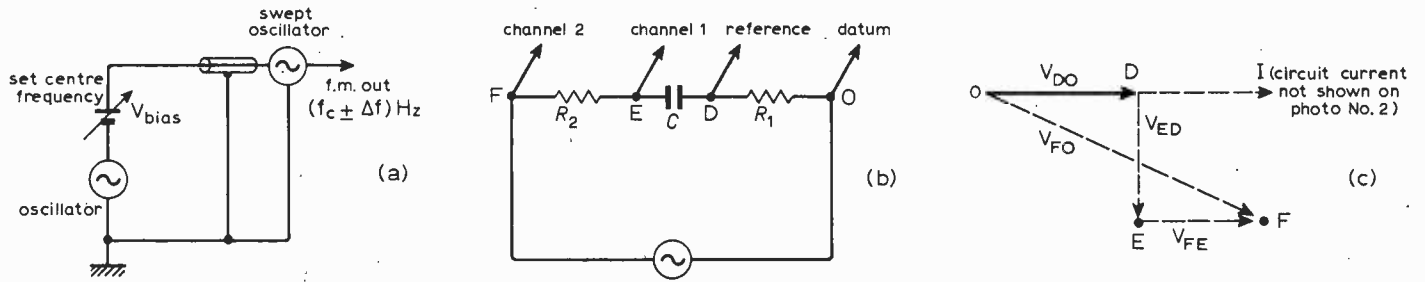
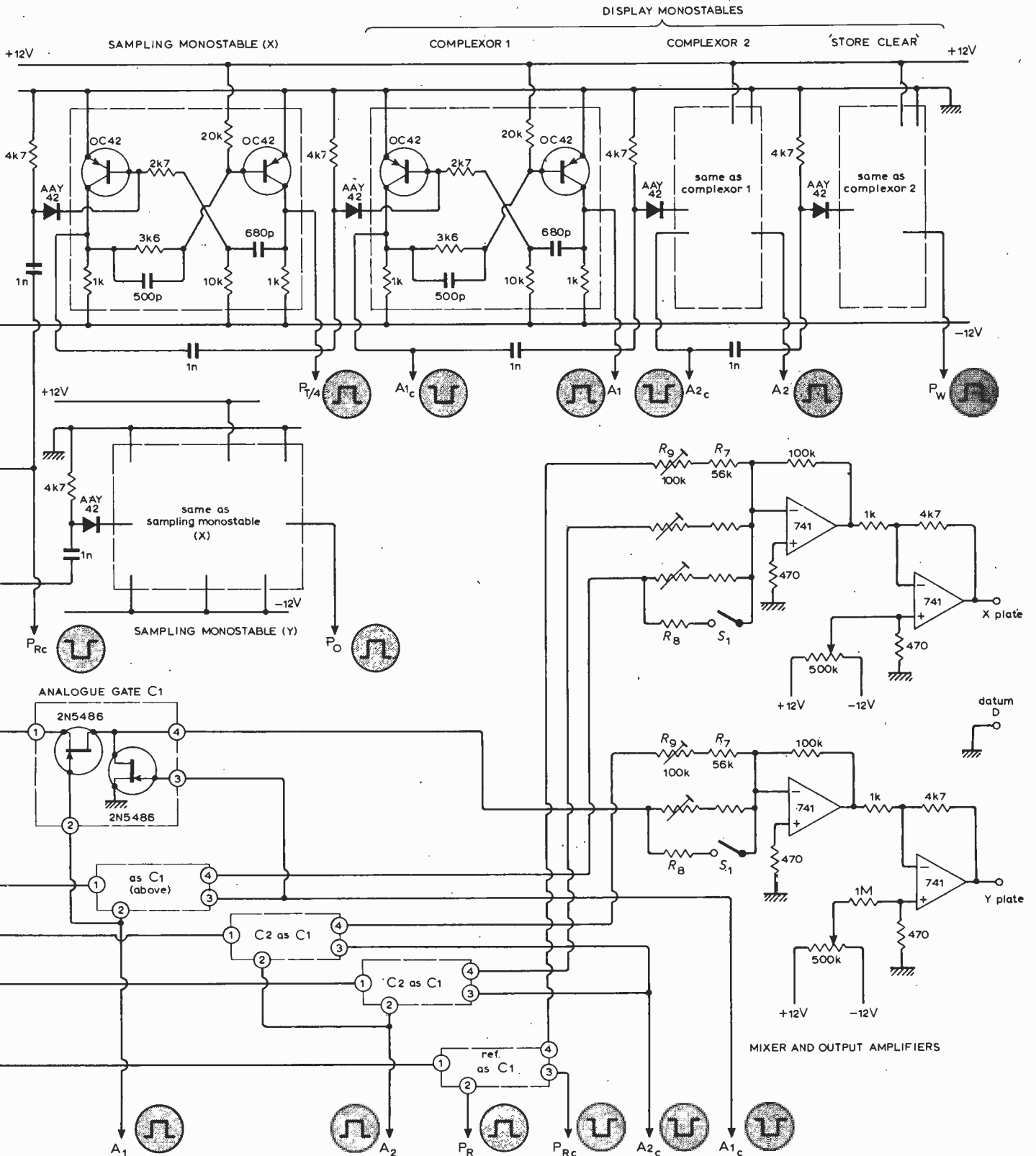

Fig. 7(a). Method of producing frequency modulation of Fig. 6(a). With no modulation set bias to give desired f_c , 50Hz in this case. Apply modulation to give desired Δf (1Hz was used to suit photography). (b) and (c) are network and diagrammatic explanation for Fig. 6(b).



potentiometer R_9 to equalize the gain for all in-phase and quadrature components. In addition, an auxiliary gain control is provided to permit individual increase in magnitude so that small-magnitude complexors are displayed to a larger scale for the convenience of the user. This switch connects resistor R_8 in parallel with $(R_7 + R_9)$ and can be used to provide either discrete changes in gain or a continuous variation, without altering the basic calibration of the display. To meet these requirements, for a gain $G \geq 2$,

$$R_8 = R_9 \frac{(1 + \xi)}{(G - 1)}$$

where $\xi = R_7/R_9$.

Finally, fixed-gain output amplifiers provide the in-phase and quadrature component drive to the x and y inputs of the oscilloscope. Typical waveforms from these amplifiers are shown in Fig. 5.

As the complexors are drawn with respect to orthogonal axes having equal scales, the oscilloscope should have an x - y facility or a simple means of connecting one of its y amplifiers to its x plates.

Display calibration

Display calibration is necessary to ensure that angular displacements and magnitudes of all the complexors are compatible. D.C. offsets are annulled at the output amplifiers, removing zero-shift from the display.

The complexor generator will provide a calibrate waveform when a signal is applied to the reference input. The calibrate waveform is in quadrature lag with the reference and by connecting it to all the other inputs it only remains to adjust each potentiometer R_9 in the mixer amplifier arms to produce coincidence of the dot complexors at exactly 90° displacement from the reference complexor and ensure that the ratio of reference to dot complexor magnitude equals that of the respective waveform amplitudes. Ideally this is unity.

To aid initial calibration and provide the user with a calibrated display, a graticule of the normal square grid format will suffice. As a useful alternative, especially for displaying loci, a graticule of the R - θ type with radial θ lines and concentric R circles could be used.

Applications

A wide variety of complexor diagrams can be displayed with the system described and as a visual aid in teaching the complexor display can be usefully integrated with lectures to provide reinforcement of a theoretical discourse. Applications include

- teaching circuit theory (see photographs (a) to (c))
- measuring transfer functions of active and passive networks
- observing faults on three-phase power systems
- displaying circle diagrams of three-phase-induction motors
- displaying phase-voltage and stator current loci of synchronous motors
- direct indication and measurement of the phase relationship between signals of the same frequency

- comparing impedances, resistances and reactances
- measuring loss angle of capacitors and Q factor of inductors
- visual presentation of modulation techniques (see photograph (d)).

Provided that all sinusoidal input signals to the complexor generator have the same frequency, the display is static. When the input signals have different frequencies, the reference complexor is displayed as a horizontal line and the dots, representing the ends of the other complexors, rotate at an angular velocity equal to the difference between their frequency and the reference. This fact is used to elucidate the principles of modulation. For instance, a carrier of frequency f_c amplitude modulated at a frequency f_s is equivalent to a carrier of constant amplitude V_c and two sidebands of amplitude V_s having frequencies $(f_c + f_s)$ and $(f_c - f_s)$. If the reference channel selects the f_c component then V_c will be a stationary horizontal line representing the carrier, while the two dots representing the sidebands will rotate in opposite directions at an angular velocity of $2\pi f_s$ radians. In a similar manner, the unit may be used to show the effects of phase or narrowband frequency modulation. In both cases, the difference frequencies must lie within the pass band of the input filter.

In conjunction with a video tape recorder, the equipment described has been successfully used in demonstrating complexor diagrams to a group of one hundred and forty students following a first course in alternating current circuit theory.

There are many other uses for an equipment of this type; the applications suggested indicate the versatility of the unit as a general purpose laboratory tool which can be exploited to suit the needs of those involved in understanding complex quantities.

REFERENCES

1. T. Palmer; 'A visual aid for use in teaching vector diagrams'. *Electronic Engineering*, vol. 23, 1951, p. 253. E. R. Laithwaite et al., 'A method of displaying vectors on a cathode ray tube'. *Proc. IEE*, vol. 101, 1954, p. 140.
2. P. Williams, 'Bandpass filters using Wien's bridge'. *Electronic Letters*, vol. 6, 1970, p. 186.
3. W. J. Albershiem and F. R. Shirlley, 'Computation methods for broad-band 90° phase difference networks'. *IEEE Trans.*, vol. CT-16, 1969, pp. 189-96.

Announcements

A course in audio techniques to be held at Norwood Technical College, Knight's Hill, London, SE27 OTX, will cover a period of 10 weeks, 18.30 to 20.30 each Tuesday commencing 3rd October. Enrolment fee is £3.

A course in modern electronic measurement techniques is to be held at Lanchester Polytechnic, Priory Street, Coventry CV1 5FB, on 14th and 15th November 1972 (09.30 to 17.30). Enrolment can be for either or both days.

A merger has been effected through Audiotronic Holdings Ltd, a new company which has been formed to amalgamate the Laskys group with the G. W. Smith business.

Proximity Switches Ltd, Progress Works, Albert Road, Aldershot, Hants, have acquired the manufacturing and marketing rights for Airmec proximity switches and the European service and sales rights for Tann proximity switches.

Allen-Bradley Co. of Milwaukee, Wisconsin, have announced they are to acquire **Morganite Resistors Ltd**, a British manufacturer of electronic components, from The Morgan Crucible Company, Ltd. of London.

Burndept Electronics (ER) Ltd, St. Fidelis Road, Erith, Kent DAB 1AU, the radio communications subsidiary of the Ever Ready Co. (GB), have announced they are to purchase **Ultra Electronics**, mobile radiotelephone business.

Creed and Co., a subsidiary of International Telephone & Telegraph Corporation, has changed its name to **ITT Creed**.

H. Tinsley & Co. Ltd., Werndee Hall, South Norwood, London, S.E.25, have signed an agreement with Wave Energy Systems, Inc. of New York, for the marketing rights for a number of W.E.S. products outside North and South America and Switzerland.

Iskra, the Yugoslavian electrical manufacturing company, have appointed H. H. Tele-Com Ltd, of 5 Kirby Street, London E.C.1, as U.K. agents to market their **telecommunications equipment**.

Portescap (U.K.) Ltd, 204 Elgar Road, Reading, RG2 0DD, have acquired the exclusive U.K. agency for Magnetic (Electric Motors) Ltd, of Switzerland, manufacturers of industrial and hospital linear actuators, low-cost and miniature a.c. servo motors, tachogenerators, amplifiers and reduction gearheads, capacitor motors, rotation vibrators and synchro servo systems.

Bantex Ltd, Abbey Road, Park Royal, London N.W.10, have concluded an agreement with Labgear Ltd, for the manufacture under licence of their tunable remote control motorized h.f. band aerial.

Circuit Integration Ltd, of Runcorn, have ceased trading and their product lines have been acquired by Fairhurst Instruments Ltd, Woodford Road, Wilmslow, Cheshire.

On behalf of Lockheed Electronics, Aveley Electric Ltd, Arisdale Avenue, South Ockendon, Essex RM15 5SA, will be marketing the 417 **data recorder**, both four- and seven-track versions.

A. V. Distributors London Ltd, 26 Park Road, Baker Street, London NW1 4SH, have been appointed sole U.K. agents for the range of Stellavox tape recorders and AMI mixer.

Bryans Southern Instruments Ltd have signed a five-year agreement with Fenlow Electronics Ltd which gives them exclusive rights to sell Fenlow's products throughout the world.

Marconi Space and Defence Systems, of Chelmsford, have been given Ministry of Defence "go ahead" to set up the production line for their "Clansman" **military v.h.f. vehicle radio**.

Pye Telecommunications Ltd, Newmarket Road, Cambridge, have received a contract to supply the first digital **vehicle location system** (Pinpoint) in the United Kingdom.

J. Parkar & Co (London) Ltd, distributors of Onkyo and Binatone audio equipment, have moved their premises from central London to Parkar House, Beresford Avenue, Wembley, HAO 1YX, Middlesex.

Allied International Co. Ltd, of Union Street, London, S.E.1, have now transferred their headquarters to Cross Lances Road, Hounslow, Middx. Tel: 01-572 2255.

Aston Electronic Developments Ltd, of Pirbright, manufacturers of closed-circuit **television equipment**, have moved to 125/7 Deepcut Bridge Road, Deepcut, Camberley, Surrey.

Letters to the Editor

The Editor does not necessarily endorse opinions expressed by his correspondents

Op-amp transfer characteristic

I was most interested to read the first article in the series Experiments with Operational Amplifiers by Mr. Clayton in your June issue, since I have recently been involved in the design of laboratory work to illustrate the properties and potentialities of op-amps. The comments I have to make relate to the oscilloscope display of the open loop transfer curve. In the choice of sweep speed and sweep repetition frequency there are two criteria which it would seem desirable to satisfy, (i) that a flicker-free display be obtained; (ii) that the sweep be slow enough for high frequency and saturation effects not to invalidate the measurement. It might not, of course, be possible to satisfy, simultaneously, both of these conditions. A practical method of determining whether (ii) is obeyed is to vary significantly the sweep characteristics and see if there is any change in the amplifier transfer curve displayed; if there is not, then the sweep speed originally chosen is suitable.

The unijunction sweep circuit given by Mr. Clayton has a fixed sweep — though it could easily be made variable — the duration of which is, using his component values, in the region of 100 ms; this corresponds to a horizontal display scale

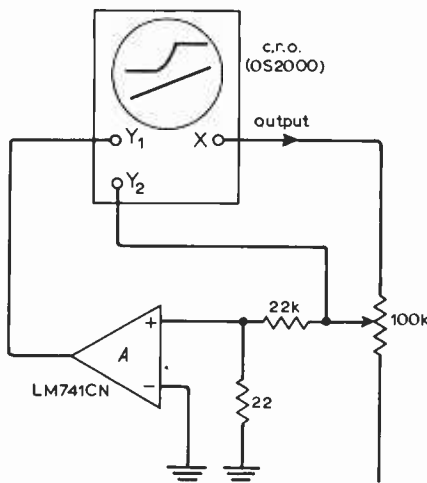

Fig. 1. Experimental set-up for transfer characteristic display.

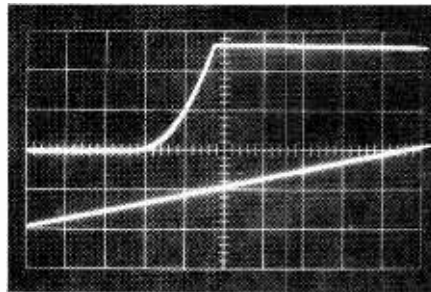

Fig. 2.

of 10 ms/cm. This figure might well be too short to satisfy (ii). To demonstrate this the circuit shown in Fig. 1 was used, a dual-trace oscilloscope with a "timebase-output" facility being available. (The 100 k Ω potentiometer permits the setting of a given mV/cm on the horizontal axis by using the $\times 2$ channel for calibration purposes.)

The upper traces in Figs 2 and 3 show, respectively, sweep speeds of 10 ms/cm; 100 ms/cm; vertical sensitivity being 10 V/cm. The lower traces have a vertical sensitivity 1 V/cm.

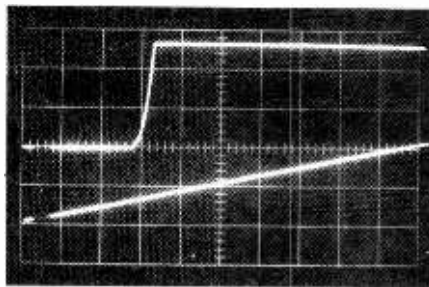

Fig. 3.

Clearly, the upper trace in Fig. 3 indicates a higher gain than that in Fig. 2. Evidently the sweep circuit given by Mr. Clayton can only be relied on to give the general shape (normally, of course, all that is required) rather than an accurate representation of the transfer characteristic of some op-amps, such as the 741 type. Thanks are due to Mr. R. Bishop for assistance in the photography.

B. L. Hart,
North East London Polytechnic,
Dagenham, Essex.

Doppler effect — 1

I am indebted to Cathode Ray for a great deal of down-to-earth practical instruction. With due deference, I would like to suggest that on the subject of loudspeaker Doppler distortion (May issue) he is guilty of over simplification. The general formula for Doppler distortion is indisputable; I question its application to the cone of a loudspeaker. The significant cause of confusion seems to be the precise definition of what constitutes relative movement between the source, i.e. the loudspeaker cone, and the medium, i.e. the air. Let us suppose that the loudspeaker cone is a piston acting in a tube. Making all the usual assumptions of perfection, the cone is not moving through the air but acting as a transducer feeding a transmission line. To achieve movement through the medium, we must create a gap between the cone and the tube wall and either blow down the tube or move the loudspeaker. Relative movement is better defined by saying that it is represented by displacement of air from one side of the loudspeaker plane to the other. I make no claim of originality in saying that movement through the air means that air at the front is being transferred to the back. What we should remember is that the baffle or enclosure is engineered to prevent this.

Having made the foregoing statements, the relationships between Mr. Doppler, baffles, cones, air and amplifiers become clearer. The amplifier is delivering power towards cone movement. After allowing for all the usual resistance encountered when we try to do anything useful, we see that the power is being dissipated in two ways. First, it is being absorbed by the radiation resistance of the air and converted into desired sound waves. This is analogous to the correctly fed transmission line and Mr. Doppler has no jurisdiction whatsoever. Secondly, power is directed to the movement of air from one side of the cone to the other. This is equivalent to movement through the medium and besides being wasteful, gives Mr. Doppler full opportunity to take effect. The solution is to use a big enough baffle or suitable enclosure, reduce air leakage from front to back and consequently apparent movement through the air.

Air has distributed mass, compliance and resistance. The generation and propagation of sound waves is analogous to the propagation of electrical waves in a transmission line. The essential difference is that the transmission line propagates in one dimension, length. The air propagates in three dimensions. We also tend to feed transmission lines from one end, rather than at a point within the length. I am unaware of any Doppler difficulties in combining signals for simultaneous transmission down a transmission line. If we had sliding connections and unwound the line in London and wound it up in Manchester, or moved the termination, we would encounter, amongst many other difficulties, Doppler distortion.

One can predict the possibility of frequency modulation by feeding a line and allowing signal leakage into another line. This would be equivalent to front to back cancellation in a loudspeaker. The resulting Doppler effect could be used to frequency modulate one signal by another. I conclude my case by suggesting that Doppler effect is significant only when a loudspeaker is inadequately baffled or incorrectly matched to the air load.

P. J. Unwin,
P. & M. Services Ltd,
Rochdale, Lancs.

Cathode Ray replies:

Let us first of all dispose of the electromagnetic wave analogy. It is unsound—in more senses than one! Not only is no medium involved; the waves are transverse, not longitudinal, so the Doppler question does not arise.

Next, to take an unpractical case, but one most favourable to Mr Unwin, suppose the loudspeaker cone feeds straight into a long tube of the same diameter, at the other end of which is the listener's ear. Then, if the loudspeaker is fed with a 1000 Hz signal, plus a 50 Hz signal of comparable strength, the 50 Hz will produce much the greater cone amplitude but the 1000 Hz will sound much the louder. Because the distance to the listener from where the 1000 Hz cycles are starting is continually changing, a condition for Doppler effect exists. However, it is open to Mr Unwin, or anyone likeminded, to prove that Doppler is exactly counterbalanced by the cyclical displacements of the air en route.

I would like to justify my down-to-earth reputation with Mr Unwin by suggesting that rather than arguing in armchairs about it someone should find out what happens in practice. Given (or lent) a wave analyser, it should be easy enough to demonstrate the Doppler effect, or its absence, with any chosen audio equipment. Supply it with two signals such as suggested (one of these can be derived at no cost from the mains). Check with the wave analyser at the input to the speaker that intermodulation is negligible. Then, using a good microphone, examine the acoustic output for f.m. sidebands around 1000 Hz. Doppler effect, if present, should be a maximum on the axis and zero at 90° to it.

This seems so simple and conclusive that I find it difficult to believe that it has not been done, probably many times, and the results published. But in the backwater where I now reside I don't have ready access to references. So would Mr Unwin or someone care to have a look and report findings?

Doppler effect — 2

I read with much interest the article by Cathode Ray in the June 1972 issue and it raised in my mind an old query which has bothered me for many years.

The article states that the speed of light in space is never more than c which is 299,792,800 m/s. The article goes on to

show that there is no aether or other medium in space.

The question then arises: Allowing that there is nothing worth considering in space, certainly no medium for carrying electromagnetic radiations, how are we measuring the speed of light?

What I mean is, with respect to what we are saying that the speed of light is constant?

If we say that the speed is with respect to space then I ask "What space; the space round the Earth? Or the space round the sun? Or the space round a distant star?"

Let us consider the viewpoint of some imaginary humanoid dweller in the more distant parts of the universe which are receding from us very fast. If he were to measure the speed of light in his space would it be 299,792,800 m/s? I feel sure that it would. If we can visualize him on his distant planet for a moment we can see that sometimes his measured light would be travelling towards us; and conversely at other times it would be travelling away from us. In the first case the speed of his light relative to us would be very much greater than c . In the second case the speed of his light relative to us would be very much less than c .

If we accept the conventional view that because he and his world and space are travelling very fast they have increased in mass and in speed but it wouldn't explain the decrease in speed, would it?

Furthermore is it not very conceited of us to suppose that our speed of light as measured round the Earth is the one which pertains in all the universe?

Would it not explain the problem much more clearly if we were to suppose that the speed of light is only constant in space relative to the nearest gravitational body?

There is another associated problem which comes to mind: If one believes the theory of relativity, I understand that if one travels in a straight line at a given speed and then returns along the same line at half the speed one arrives back at the start a small amount of time earlier than if one stayed at the start all the time without moving. This would apparently lead to the ridiculous supposition that the person who stayed behind would hear the first pip of the B.B.C. time signal at the same time as the person who went and returned would hear the second pip of the time signal. I believe this led many people to suppose that time is a fourth dimension (Gamov, Minkovski etc.)

A. F. Jervis,
Bournemouth.

Cathode Ray replies:

The basis of Einstein's Special Theory of Relativity (which is what Mr Jervis is discussing) is that the universe contains no observation point (or "frame of reference", in scientific terms) that is more valid than any other for measurements of time, speed, distance, etc. He would have agreed with Mr Jervis that it was conceited to suppose that our earth was any more entitled to be regarded as a reference than

anywhere else. If there were an all-pervading medium (aether), then it could be used as a reference, just as the atmosphere can be used as a reference in measurements involving the speed of sound. But every experiment that should have given a positive result if there had been an aether conspicuously failed.

For instance, the experiment proposed by Mr Jervis. The fact that the humanoid on the distant planet finds that light travels past him with velocity c whether it is moving towards or away from the earth does not mean that human physicists can find any difference between the velocities of the two beams. The relative velocity between the two planets means that observations made on each by the inhabitants of the other are affected by changes in measuring instruments according to the quite simple formulae given in any treatise on relativity. (A relatively simple explanation is the subject of the last chapter of Scroggie's 'The Electron in Electronics'.)

It admittedly does go against the grain to accept that light travels in space with the same velocity c regardless of movements of the observer, so that observers moving at high speeds relative to one another nevertheless get the same value for c but one really has no alternative that will stand up.

The problem about people who make their journeys into space and come back looking younger than those who stayed behind continues to be discussed, and recently an experiment was described in which an extremely precise atomic clock was to be flown at high speed round the earth and compared with one left at base. I have not heard whether the experiment was carried out, and if so with what result. In the case described by Mr Jervis there would be no cause for disagreement about which pip was actually being heard, but the returning traveller (if he had a sufficiently precise timepiece) might claim that by his reckoning the B.B.C. time signal was a trifle fast.

Simple electronic multimeter

Having a requirement for an electronics multimeter, I was very interested in Mr. Linsley Hood's neat design which appeared in the June issue.

I was surprised to read that the ohmmeter circuit shown in Mr. Linsley Hood's Fig. 3, was chosen because of its wider resistance spread. This implies that an inherent characteristic of the Fig. 4 ohmmeter circuit is a restricted resistance scale. No indication is given regarding the resistance ranges of the Fig. 4 ohmmeter, but with an input resistance to the measuring system of 0.75M Ω only low resistance values can be measured with any accuracy. This type of ohmmeter circuit requires that the input resistance of the measuring system is very high in comparison with the resistance being measured. If this condition is satisfied the resistance coverage of the two ohmmeter circuits is identical.

The input resistance to the measuring circuit may be made less demanding, if it is convenient to interchange the circuit positions of the reference and unknown resistances.

D. Jones,
Aldeburgh, Suffolk.

The author replies:

Mr. Jones is quite right. If I had stopped for a moment to calculate the relative characteristics of the ohmmeter systems, I would have realized that they were in fact identical.

As it was I had fallen into the pitfall of repeating without question a fallacy which I had believed for many years. In fact, in the case of the "series battery" connection, the mid-point of the ohms scale is for an external "R" equal to the preset resistor and meter circuit in series, with 9R being 10% f.s.d. and $\frac{1}{9}R$ being 90% f.s.d.

In the case of the "parallel battery" arrangement, if "R" is the value of the unknown in parallel with the meter circuit resistance (which is high) 50% f.s.d. = "R", 10% f.s.d. = $\frac{1}{9}R$ and 90% f.s.d. = 9R.

J. L. Linsley Hood.

Low-noise audio amplifiers

I have read with interest the instructive article by Mr. Walker on low-noise audio amplifiers (May issue, p.233). There are, however, a few points arising which may be worth comment.

The difficulty with shunt feedback systems (virtual earth configurations) is, of course, that the input signal is attenuated, in the ratio of the total source resistance to the input impedance of the amplifier device, prior to amplification, and this inevitably worsens somewhat the signal-to-noise ratio at the input to the amplifier.

However, many modern low-noise transistors, such as the Texas Instruments BC214 and the Motorola 2N5089 have an optimum source resistance which is possibly an order of magnitude greater than that of the examples quoted by Mr. Walker (2N4126 and TIS97). Moreover, in such devices both the total noise figure and the noise bandwidth are improved by the use of relatively low collector currents (10 μ A or less) and source resistances of the order of 50-100k Ω , as shown in my Fig. 1 for the Motorola 2N5089.

Obviously the use of such devices with a low impedance series feedback system will lead to a substantial worsening of the possible noise figures, unless a fairly large input padding resistor is employed. In this context the increased input impedance of the transistor, at such low collector currents, reduces the attenuation due to the source resistance in a shunt feedback system, which lessens the difference between the two systems.

Finally, it is worth while drawing attention to one residual advantage of the shunt feedback system, which may make it attractive in spite of a possibly worse noise figure. This is that the negative feedback is applied directly to the signal

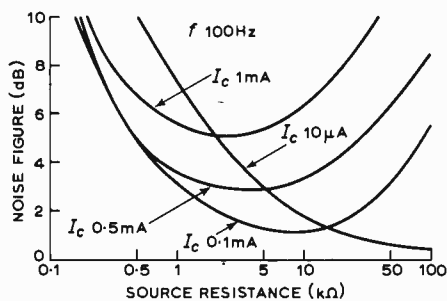
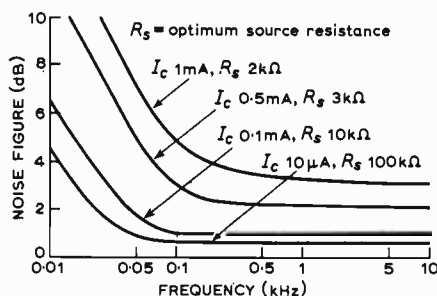

Fig. 1. Noise figures for the Motorola 2N5089.

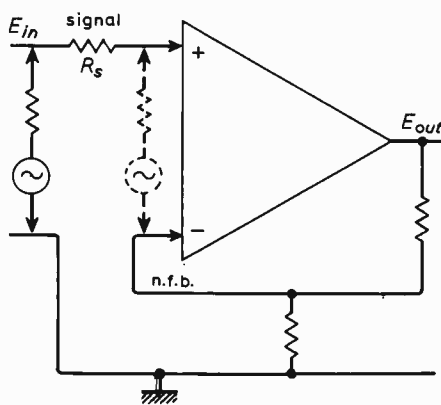

Fig. 2.

input point so that the steady state distortion may, at least in theory, be reduced indefinitely by the use of increasing amounts of negative feedback. In the series feedback system (my Fig.2), any transfer non-linearities between the inverting and non-inverting inputs will appear in series with the feedback path and the maximum linearity of the system is limited by this consideration. When a single transistor is used as the input device this point may be only of academic interest, but this is not necessarily the case when using an operational amplifier.

J. L. Linsley Hood,
Taunton.

Soldering aluminium alloy.

With all due respect, News of the Month (July issue) be blown!

My grandfather — God rest his soul — showed me how to solder aluminium through mineral oil during World War II. He used to solder ali patches onto frost-bitten alloy engine cylinder heads, instead of welding the heads. This was

done because of the shortage of gas and the time taken to pre-heat an alloy casting in a muffle to enable welding to be done without cracking the casting.

I have been using the same method since then to solder ali chassis in the construction of amateur radio equipment without any trouble, and only in June 1971 I demonstrated the very same method in the B.O.A.C. workshops where I am employed. I still have the demonstration piece, if anyone would care to inspect it, which is soldered by its *edge*, not on a flat surface, and is still giving good service in the equipment for which it was made.

Corrosion and electrolytic action have not been found to occur where the oil used was clean and pure mineral, and where the joint was properly washed and protected from the air afterwards, by a light coating of Vaseline or lacquer. Even an untreated joint should not deteriorate for a considerable time, by my experience.

Walter S. Williams,
Ewell, Surrey.

Lunar epic

Regarding the Apollo 16 picture clarity (News, June issue), there is a fourth possibility that immediately suggests itself.

It also offers a more obvious need for secrecy and the transmission of the signal to Hollywood, foundation of film-making. A well simulated film set, two quick thinking actors, experienced in mime, a good cameraman behind the lens, result — perfect pictures.

Amazing what can be done with a 0.2s time lag!

C. F. Green,
Waltham Abbey, Essex.

Low-cost horn loudspeaker

In reference to the May 1970 *Wireless World* article Low-cost Horn Loudspeaker System, I would like to point out that the question raised concerning horn operation near cut-off in the mentioned Klipsch paper is answered in a later paper: A Note on Acoustic Horns, *Proceedings of the I.R.E.*, Vol. 33, No. 7, July, 1945.

David R. Schaller,
Milwaukee, Wis., U.S.A.

More illegal listening?

With reference to Mr. Cox's letter in *Wireless World*, June 1972, I too pick up police radio messages, on the cassette tape recorder which I carry in the car for entertainment.

It would be interesting to know if the Ministry of Posts & Telecommunications regards a tape recorder as a radio receiver in this particular case.

Thomas H. Pattinson,
Totland Bay, Isle of Wight.

Electronic Building Bricks

26. More logic gates

by James Franklin

In Part 25 we saw how a set of conditions required to start a passenger lift could be satisfied by an electronic gate operating to a set of rules taken from deductive logic. Hence the electronic device was described as a logic gate. The rules were in fact the truth table for the *conjunction*—two statements linked by the truth-functional operator 'and'. Thus the logic gate concerned is known as an 'and' gate. This article looks at two further logic gates, with actions corresponding to the truth-functional operators 'not' and 'or'. In deductive logic the operator 'not', when applied to a statement, produces what is called, obviously, a *negation*. The operator 'or' (like 'and') must link two statements, for example *p* 'or' *q*, and the resulting expression is called a *disjunction*.

Suppose that our electric lift control system has a further requirement, that the lift should stop if a 'stop' button in the lift is pressed or the lift doors are open. The state of the doors is monitored by a further door sensing switch, which is actuated when the doors are open. Let us once again list the possible states of the 'stop' button, door sensing switch and lift motor and give them 'shorthand' symbols:

- Stop button not pressed ○
- Stop button pressed ●
- Door switch not actuated ◇
- Door switch actuated ◆
- Lift motor not running □
- Lift motor running ■

What the control device, Fig. 1, is required to do can be tabulated by listing all possible combinations of the 'stop' button and door switch and putting alongside them

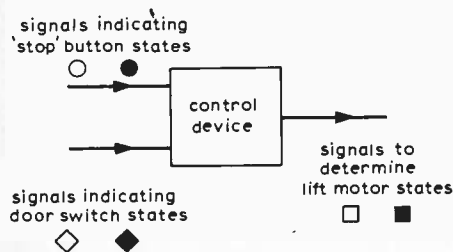

Fig. 1. Control device for stopping a lift when a 'stop' button is pressed or the doors are open (or both).

the required states of the lift motor, thus:

| | | | |
|---|---|---|---|
| e | ○ | ◇ | ■ |
| f | ● | ◆ | □ |
| g | ○ | ◆ | □ |
| h | ● | ◆ | □ |

As explained in Part 25, a logical analysis of this kind is called a truth table and can be expressed in terms of the *T* (true) and *F* (false) symbols used in the truth tables of deductive logic because the 'stop' button, door switch and lift motor are all two-state (on/off) electro-mechanisms. In this case we will decide to call the states represented by the blacked-in symbols true (*T*), and consequently the opposite or contradictory states will be called false (*F*). Then we have

| | | | |
|---|---|---|---|
| | ● | ◆ | ■ |
| e | F | F | T |
| f | T | F | F |
| g | F | T | F |
| h | T | T | F |

where the expressions *e, f, g, h* correspond to the conditions *e, f, g, h* in the 'requirements' table.

Now this table does not happen to be, as in Part 25, the truth table for a particular function in deductive logic. But it does happen to represent the *opposite* of the relationships for a particular function—the *disjunction* mentioned above. The truth for a disjunction, that is, for the 'or' operator and the 'or' gate,* is:

| | | |
|---|---|---|
| F | F | F |
| T | F | T |
| F | T | T |
| T | T | T |

As can be seen, the *F* and *T* symbols in the right-hand column are the opposites of those in the right-hand column of the previous truth table. Therefore if we wish to use an electronic control device whose action corresponds to that of the 'or'

* More precisely the 'inclusive or' gate, because, as the associated table shows, the truth of each compound statement does not result from the truth of only one of the component statements (2nd and 3rd lines) but also results from the truth of both of them (4th line).

operator—namely an 'or' gate (Fig. 2)—we must find some way of reversing its operation.

This can be done by means of a gate whose action corresponds to the logic function *negation* mentioned above. In deductive logic the truth table for negation is:

| | |
|----|---|
| ~T | F |
| ~F | T |

where the symbol '~' stands for the truth-functional operator 'not'. (This table is simply a formalization of the statements that what is not true is false and what is not false is true.) The logic gate which acts in accordance with these rules is called a 'not' gate (Fig. 3). Used in a circuit, it will change a signal representing one state—for example one of the states shown by blacked-in symbols above—to a signal representing the opposite state—the state shown by the corresponding open symbol.

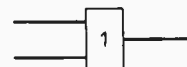

Fig. 2. Symbol for an 'or' gate.

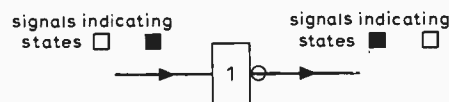

Fig. 3. Symbol for a 'not' gate.

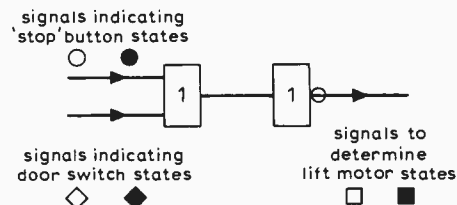

Fig. 4. Combination of an 'or' gate and a 'not' gate satisfying the requirements of the Fig. 1 control device.

Thus we can use the 'not' gate to change the signal representing the state ■ (or *T*) into the required lift motor state □ (or *F*), and vice versa. How this is done is shown in Fig. 4. The 'not' gate is connected to the output signal path of the 'or' gate, so that it negates, or reverses, the output signals representing ■ and □ and thereby gives the required states of the lift motor, in response to the control signals, set out in the first, 'requirements' truth table. For example, when signals representing ● and ◇ are applied simultaneously to the 'or' gate, the output of the gate is ■, but the 'not' gate changes it to the required □.

The combination of 'or' and 'not' gates shown in Fig. 4 is often considered as a composite 'not-or' gate, and in electronic form this is available as a unit called a 'nor' gate. Similarly the combination of an 'and' gate and a 'not' gate ('not-and') is available as an electronic 'nand' gate.

Experiments with Operational Amplifiers

3. Resistive feedback circuits

by G. B. Clayton,* B.Sc., F.Inst. P.

An operational amplifier is normally used in a negative feedback circuit, and the performance of the circuit is then primarily determined by the magnitude of the external components connected to the amplifier. Examples of the basic operational feedback amplifier configurations using resistive feedback are illustrated in Fig. 3.1.

It is instructive to verify the performance equation for each circuit. Input signal terminals are initially earthed and the offset balance potentiometer adjusted to give zero voltage at the output of the amplifier. An input signal is applied and input and output voltages are measured; resistor values are changed and the measurement is repeated. Both d.c. and a.c. signals may be applied, and an oscilloscope used to monitor and measure a.c. signals. Typical waveforms obtained when the circuit of Fig. 3.1(b) is used to add together a triangular wave and a square wave are shown in Fig. 3.2. Note that if the signal generator has any d.c. offset it may be necessary to apply a.c. signals to the amplifier through a d.c. blocking capacitor.

In the circuit of Fig. 3.1(c) the two inputs should initially be connected together and a sinusoidal signal applied to them. Resistor R_2^* should then be trimmed in order to eliminate the common mode signal at the output.

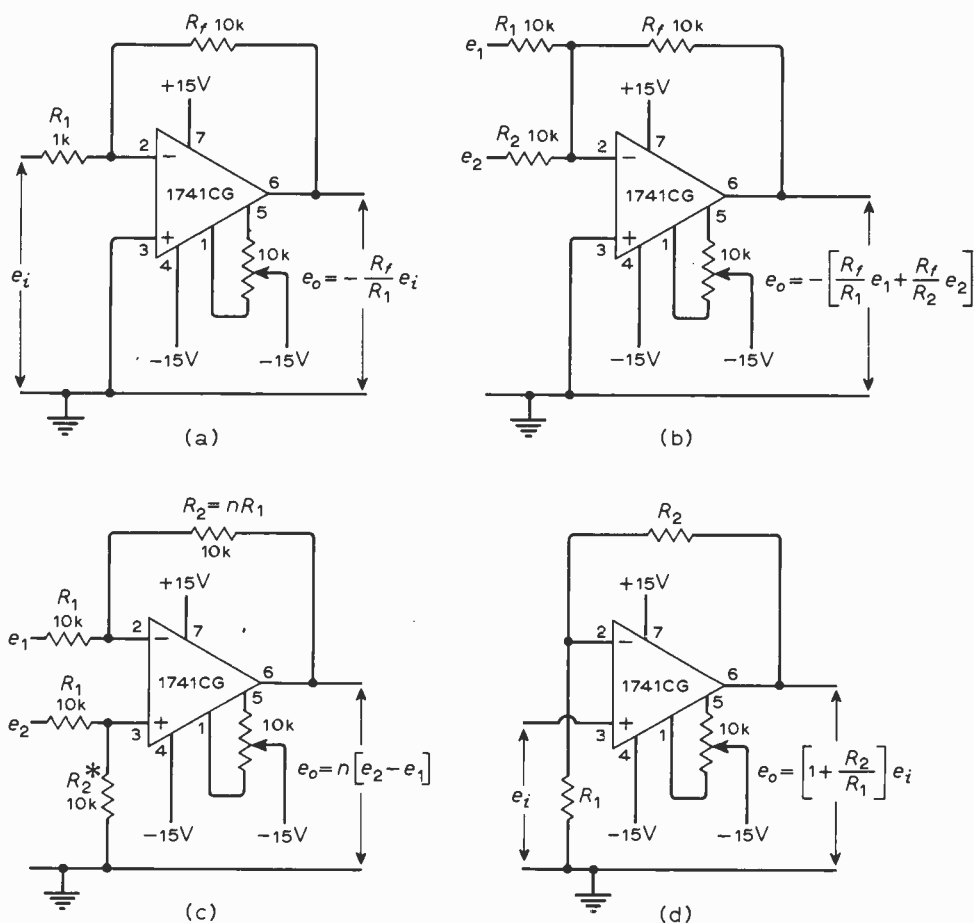

Fig. 3.1. Different arrangements of op-amps with resistive feedback: (a) simple inverter; (b) inverting adder; (c) subtracting amplifier; (d) non-inverting amplifier.

Closed loop gain and bandwidth

The bandwidth of a feedback amplifier is dependent upon the magnitude of the closed loop gain. The effect may be investigated for the follower circuit of Fig. 3.1(d). A typical set of experimental results is shown in the table below.

| R_2 (Ω) | R_1 (Ω) | gain (dB) | frequency at which gain falls by 3dB (f_c) | $\log f_c$ |
|--------------------|--------------------|-----------|--|------------|
| 10k | 10k | 6dB | 850kHz | 5.93 |
| 10k | 1k | 20.8dB | 97kHz | 4.99 |
| 10k | 100 | 40dB | 10kHz | 4.00 |
| 100k | 100 | 60dB | 1kHz | 3.00 |

In performing the test the input signal amplitude should be adjusted to give an output signal of amplitude less than one volt, in order to avoid the effects of slew rate

limiting at the output. A d.c. path must be provided for the bias current drawn by the non phase-inverting input terminal of the amplifier.

Results are plotted on a log graph in Fig. 3.3. The value obtained previously for the open loop gain of the amplifier is also shown in this graph.

Current to voltage converter

An operational amplifier may be used to measure current in two ways. The current may be converted into a voltage by passing it through a resistor and the voltage amplified by the operational amplifier connected

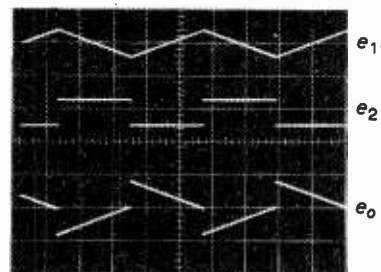

Fig. 3.2. Summation of triangular wave, e_1 , and square wave e_2 to give e_0 in circuit of Fig. 3.1(b). Vertical scale 2V/div.; horizontal 1ms/div.

*Department of Physics, Liverpool Polytechnic.

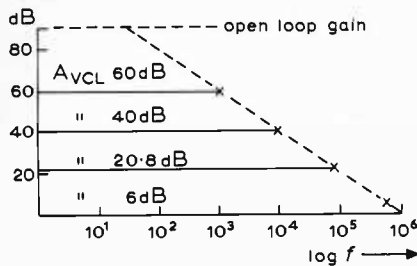

Fig. 3.3. Results of tests showing dependence of bandwidth on closed loop gain.

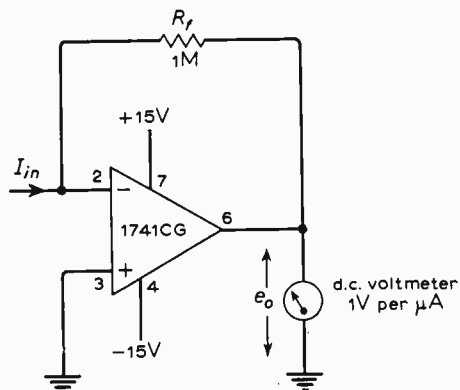

Fig. 3.4. Simple current to voltage converter.

as a non-inverting feedback amplifier. Alternatively the current may be injected directly into the summing point of the amplifier connected in the inverting configuration.

4. Operational integrators

An operational amplifier, with negative feedback applied to it via a capacitor connected between amplifier output terminal and phase inverting input terminal, may be used to perform the operation of integration. A circuit for a simple operational integrator is shown in Fig. 4.1; if the performance of the amplifier is assumed to be ideal the response of the circuit is described by the equation

$$e_o = -\frac{1}{CR} \int e_i dt \quad (4.1)$$

The time constant $T = CR$ is called the characteristic time of the integrator; it is sometimes convenient to think of $1/T$ as the gain in terms of V/s output per volt input.

Measurement of integrator drift

In the practical circuit shown in Fig. 4.1 amplifier input offset voltage and bias current cause a continuous charging of capacitor C even when e_i is made zero. The output of the single integrator thus drifts with time and the amplifier eventually saturates. With zero applied input signal (resistor R connected to earth), the drift rate is given by the relationship

$$\frac{de_o}{dt} = \pm \frac{V_{io}}{C} + \frac{I_b^-}{C} \quad (4.2)$$

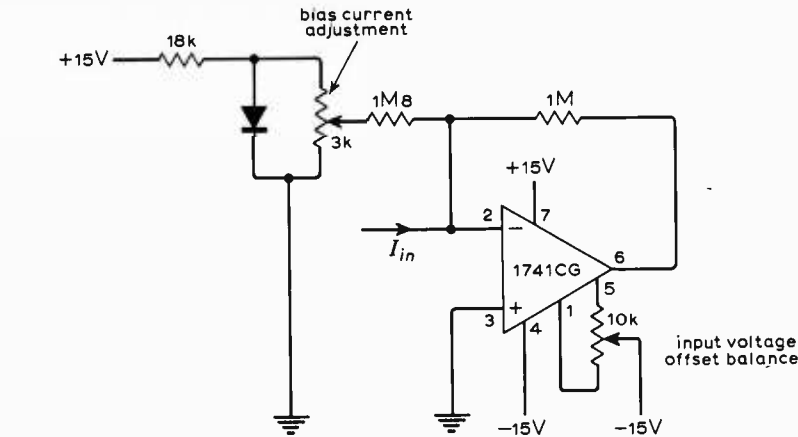

Fig. 3.5. Circuit for adjustment of input voltage offset and input bias current.

Under these circumstances the current is forced to flow through the feedback resistor and the output voltage of the amplifiers is:

$$e_o = -I_{in}R_f$$

The current is converted into a voltage with a scaling factor R_f volts per amp.

A simple circuit for a current to voltage converter is shown in Fig. 3.4. In this circuit the effective input resistance is very small. This means that a current measurement made with the circuit introduces a negligible voltage drop in the measurement circuit. The output voltage offset with zero input current is typically 0.2V.

If the circuit is to be supplied by differing source impedances or if R_f is to be changed (for a change of scale), output offset should be nulled by separate balancing of both input voltage offset and input bias current. A circuit which provides for these adjustments is shown in Fig. 3.5. Input offset voltage is balanced first. Pins 2 and 3 are shorted together and the 10kΩ potentiometer is adjusted for zero amplifier output. The short is now removed and with zero input current the bias current potentiometer is adjusted so that the amplifier again gives zero output.

V_{io} is the amplifier input offset voltage; I_b^- is the bias current drawn by the phase inverting input terminal of the amplifier.

A practical test for the validity of eq. (4.2) can be made by measuring drift rates for various values of capacitor C and resistor R . The following test procedure is suggested. The output of the integrator is applied to the d.c. coupled vertical amplifier of an

oscilloscope; the input end of resistor R is earthed. The timebase of the oscilloscope is set to free run at a slow rate (say 1 div/sec). The integrator output is initially set to zero by shorting capacitor C . The short is removed and the drift rate is determined directly by observation and measurement of the slope of the oscilloscope trace. This slope may be positive or negative; it gives the sign of the drift, which is significant, and should therefore be noted. If an oscilloscope with slow sweep speeds is not available the output of the amplifier may be measured with a centre-zero voltmeter. Drift rates may then be found by measuring the change of voltage that takes place in a measured time period. The time period should not be so long that the amplifier drifts into saturation.

A typical set of experimental results is shown in the table below.

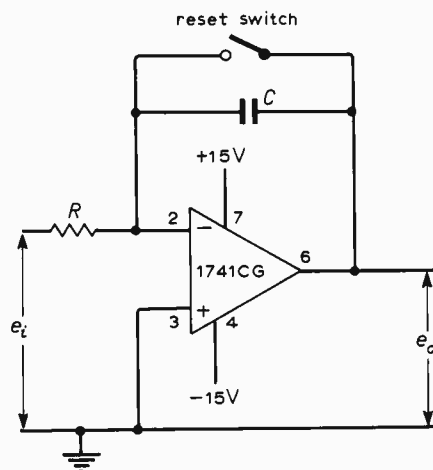

Fig. 4.1. Simple integrator.

| | R (Ω) | C (F) | $\frac{1}{C}$ | $\frac{de_o}{dt}$ |
|-------------------------|------------|------------|-----------------|-------------------|
| $CR = 2 \times 10^{-3}$ | 39k | 50n | 2×10^7 | +1.3V/s |
| | 22k | 100n | 10^7 | +0.35V/s |
| | 3.9k | 500n | 2×10^6 | -0.28V/s |
| | 2.2k | 1μ | 10^6 | -0.4V/s |
| $CR = 2 \times 10^{-2}$ | 390k | 50n | 2×10^7 | +1.76V/s |
| | 220k | 100n | 10^7 | +0.84V/s |
| | 39k | 500n | 2×10^6 | +0.16V/s |
| | 22k | 1μ | 10^6 | +0.1V/s |

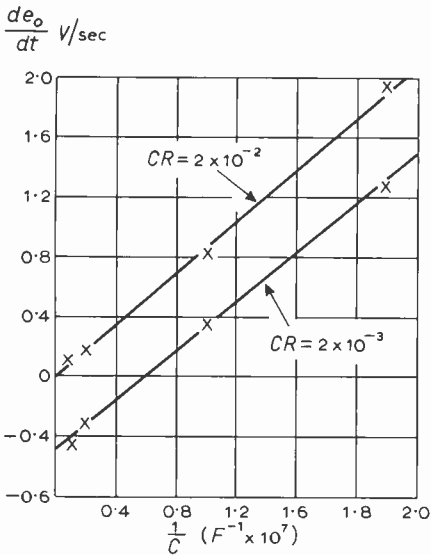

Fig. 4.2. Integrator drift rates.

For each CR value graphs of $\frac{de_o}{dt}$ against $1/C$ are plotted as shown in Fig. 4.2.

Inspection of eq. (4.2) shows that the slope of the graph gives the bias current, I_b^- , and the intercept on the $\frac{de_o}{dt}$ axis may be used to estimate a value for voltage V_{io} .

Examination of integrator action

The action of a simple integrator can be investigated using the circuit in Fig. 4.3.

A resistor equal in magnitude to the input resistor, R_i , is connected to the non phase-inverting input terminal of the amplifier in order to reduce drift due to amplifier bias current. The integrator input is connected to earth and the output is set to zero by momentarily closing the reset switch. The offset balance potentiometer (connected to terminals 1 and 5 of the i.c.) is now adjusted for minimum output drift, the output voltage being monitored with an oscilloscope or centre-zero voltmeter. It should be possible to obtain virtually zero drift.

The circuit performs the operation of integration on an input signal in the following manner. Suppose a $-1V$ d.c. signal is applied to the input resistor ($R_i = 1M\Omega$). This will draw a current of $1\mu A$ from capacitor C ($1\mu F$). In order to produce this

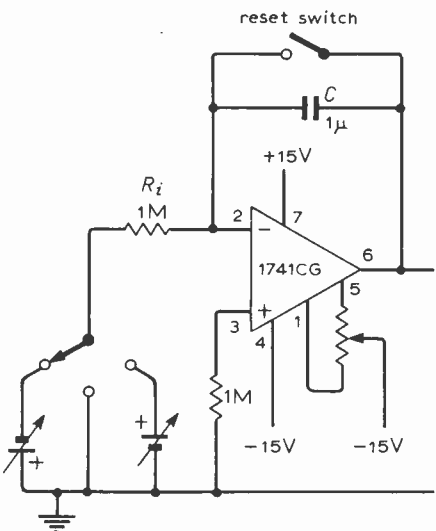

Fig. 4.3. Investigating integrator action.

current a continuously rising voltage must be generated at the output with a rate of rise equal to 1 volt/second. This rate of rise continues until the input voltage is changed or the amplifier output reaches saturation. If the input is switched to zero the output voltage of the amplifier ideally remains at the level reached when the input was removed. Suppose a $+1V$ d.c. signal is now applied to R_i . This causes a charging current of opposite polarity in capacitor C and consequently a continuously falling voltage must be generated at the amplifier output with a rate of fall of 1 volt/second.

The integrator output level at the end of some interval of time is equal to: the sum of the products of each voltage times the period of each applied voltage divided by $-RC$. The change in output level during any time period is thus proportional to the area under the input volts/time graph for that period. The action of the integrator can be veri-

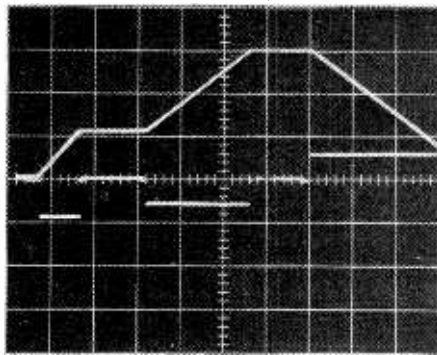

Fig. 4.4. Oscillograms showing integrator response to different input levels. Lower trace: input, 1V/div. vertically. Upper trace: output, 2V/div. vertically. Horizontal scale: 5s/div.

fied experimentally by switching the input to known d.c. levels for measured periods of time while simultaneously monitoring the amplifier output voltage (see Fig. 4.4).

Staircase waveform generator

An operational integrator may be used to linearize the output of a simple diode pump circuit. A circuit is shown in Fig. 4.5.

A constant amplitude square wave, amplitude V_{in} (approximately 10V), and frequency f (say 400Hz), is applied to capacitor C_1 . On the negative going part of the input square wave C_1 charged through diode D_1 . On the positive going part of the square wave C_1 discharges through D_2 , thus transferring a quantity of charge $C_1 V_{in}$ to the integrating capacitor C_2 and causing a step decrease in the output voltage of the amplifier. The step amplitude is equal to $C_1 V_{in}/C_2$ and the output falls in successive steps until the amplifier saturates or its output is reset to zero in some way. In the circuit in Fig. 4.5 the integrator output is reset to approximately zero by the action of the u.j.t., which is used to discharge capacitor C_2 when the voltage across it reaches some defined value. This value is determined by the d.c. voltage applied to b_2 (use about 6V).

Typical input and output waveforms are shown in Fig. 4.6. It is suggested that input frequency, input amplitude, unijunction b_2

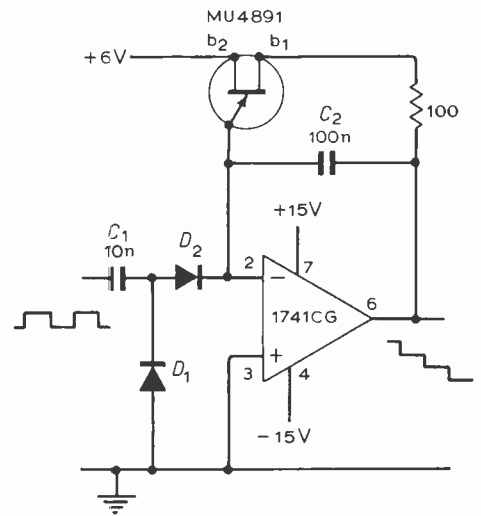

Fig. 4.5. Linear staircase generator.

and finally capacitor values be changed in turn and the effects noted.

Note. If a very low frequency square wave is used, integrator drift will cause the output to change appreciably between steps. In this case it will be necessary to add the usual offset balance potentiometer to the circuit and adjust for 'step flatness'.

Frequency to voltage conversion

The circuit in Fig. 4.5 may be modified so as to make the output of the amplifier a direct voltage of magnitude proportional to the frequency of a constant amplitude input square wave. The modification consists simply of replacing the u.j.t. with a resistor R connected in parallel with capacitor C_2 . With this modification the charge transferred per second through D_2 (given by $fC_1 V_{in}$), produces an average current

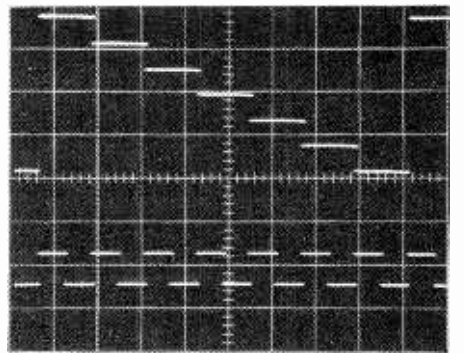

Fig. 4.6. Oscillograms showing typical input and output waveforms of Fig. 4.5 staircase generator. Lower trace: input square wave, 10V/div. vertically. Upper trace: output staircase, 1V/div. vertically. Horizontal scale: 2ms/div.

$fC_1 V_{in}$ through resistor R , and the amplifier gives an output voltage

$$e_o = -fC_1 V_{in} R$$

It is suggested that resistor R be given a value $100k\Omega$. The input frequency should be increased in steps and the output voltage measured for each value of the input frequency. A graph of output voltage against input frequency should be plotted, the slope of this line being equal to $C_1 V_{in} R$. Component values may be changed and the experiment repeated.

The Junction F.E.T. as a Voltage-controlled Resistance

2 — Practical circuits for communications use

by R. M. Lea,* M.Sc.

This article gives circuits for shunt and series automatic gain control, compression and expansion, squelch, and battery saving for communications receivers. The author concludes this two-part article by arguing that a.g.c. circuitry using junction f.e.t.s could be integrated into a.f. amplifier chips at very low cost. Part 1 of the article covered design points of a.g.c. systems and how to minimize unwanted effects.

The first article showed that the saturation region of the channel resistance characteristic of a junction f.e.t. renders the device suitable for operation as a voltage-controlled* resistance. To demonstrate the ability of the device to operate in this role, a shunt a.g.c. system for an audio amplifier has been designed and constructed (Fig. 9).

The circuit has been designed to provide a.g.c. of an audio amplifier having the following characteristics

| | |
|--|---------------|
| overall voltage gain | 54dB |
| input impedance | 50k Ω |
| output impedance | 5 Ω |
| sensitivity for maximum 'undistorted' output | 8mV r.m.s. |
| 3-dB bandwidth | 250Hz to 3kHz |

To avoid l.f. instability, two preset resistors are incorporated in the circuit. The 10k Ω potentiometer in the collector of the BC108 driver transistor controls the attack time and is adjusted to prevent oscillation for 250-Hz signals of amplitude greater than the a.g.c. threshold.

*Electronics Dept, Southampton University, now at Brunel University.

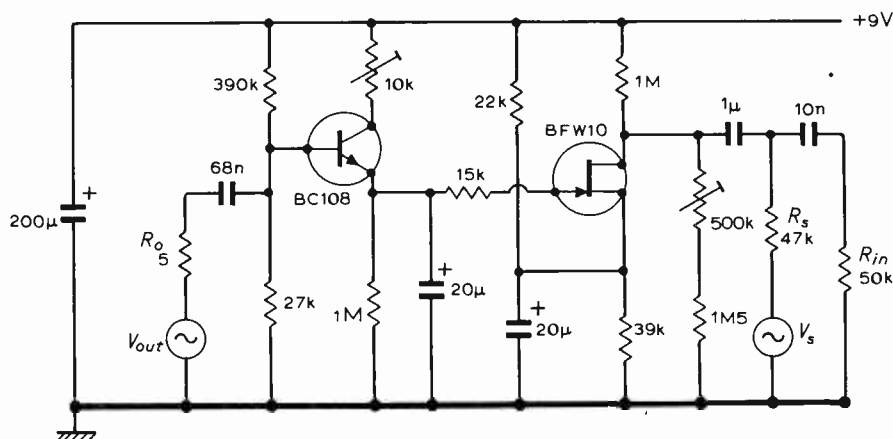

Fig. 9. Circuit of shunt a.g.c. system for voice operation (3-dB frequencies are 250Hz and 3kHz).

The 500k Ω potentiometer connected to the drain of the f.e.t. is adjusted to minimize the drain-source voltage for 250-Hz signals of amplitude well below the threshold level, without causing significant signal attenuation. By this means the parasitic a.g.c. attack due to voltage spikes at the drain of the f.e.t. is eliminated.

| | |
|--|--------------|
| Performance of the shunt system is shown in Fig. 10 and its specification is | |
| threshold | 3.3V peak |
| attack time | 20 to 50 ms |
| recovery time | 15s |
| attenuation for 3dB increase in amplifier output | 40dB |
| current consumption | 200 μ A† |

†Large peaks of input signal may cause instantaneous current of up to 5mA.

Suggested series a.g.c. system

A suggested circuit for the series system shown schematically in Fig. 3(b) is shown in Fig. 11. Designed according to the guidelines already given, it provides a.g.c. of an audio amplifier having the above performance. Input impedance of the

amplifier has been changed to 10k Ω to give a wide range of attenuation.

Protection against l.f. instability is provided in the same way as for the shunt system. The series system should not suffer parasitic a.g.c. action because the audio amplifier is fed from the source of the f.e.t., which is at a constant potential.

Total current consumption of the series system should be a little more than 1mA. This increase over the shunt system is necessary because of the class A operation of the driver transistor.

Feedback series a.g.c. system

An example of a series a.g.c. system employed in the feedback loop of a simple pre-amplifier and driver stage is shown in Fig. 12. The a.g.c. system itself is that shown in Fig. 6 with a coupling capacitor omitted, and although a series system, the driver circuit is that shown in Fig. 7(a) for a shunt system, as channel resistance must decrease with increasing amplifier output.

Volume compression and decompression

Any of the series or shunt a.g.c. circuits discussed so far could be used for volume compression and decompression of audio signals with a simple modification to speed up the recovery of the v.c.r. stage so that the attack and recovery rates are the same.

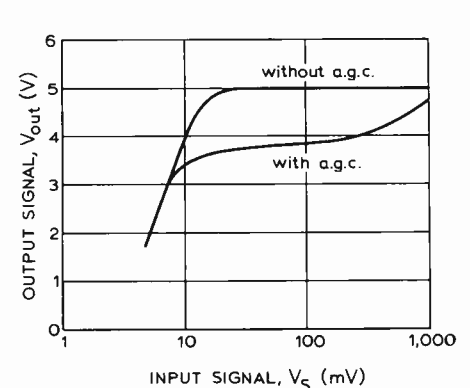

Fig. 10. Performance of Fig. 9 circuit. Attack time is tens of milliseconds and recovery time 15 seconds.

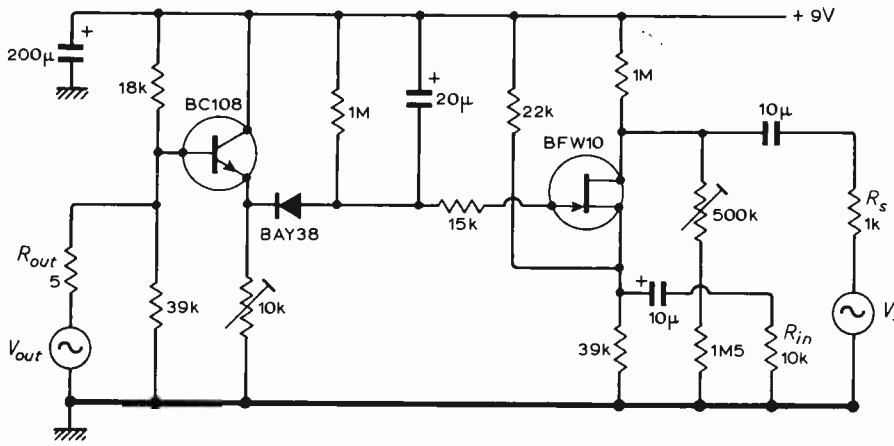

Fig. 11. Series a.g.c. circuit has same performance as shunt circuit.

Fig. 12. Simple pre-amplifier and driver with a.g.c. circuit of Fig. 6 incorporated into the feedback loop. Although a series circuit, it uses the shunt driver of Fig. 7(a).

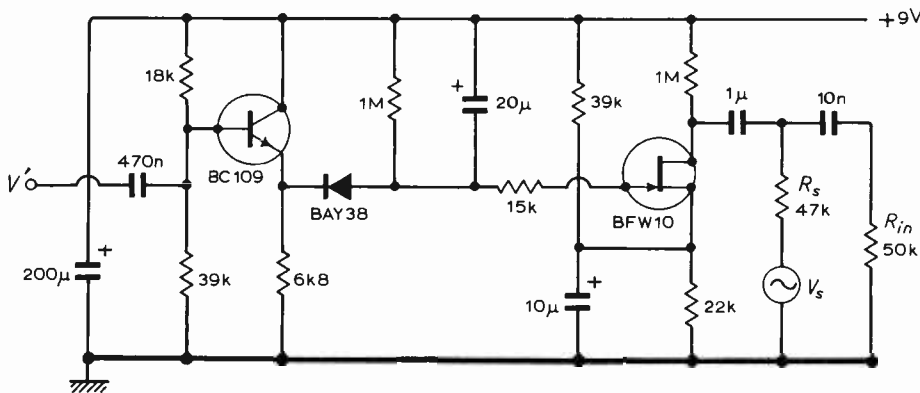
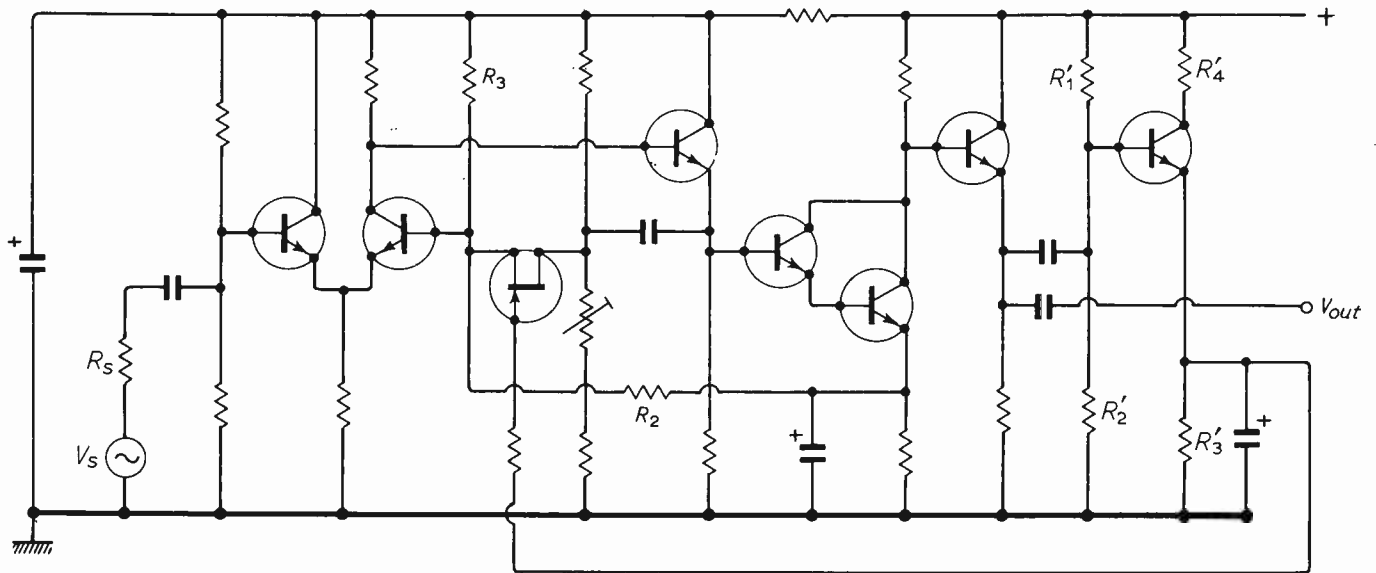

Fig. 13. Squelch system using shunt circuit. Output of the receiver detector is shown as V'_s . Signal at V' is provided by pre-amplifier at Fig. 14.

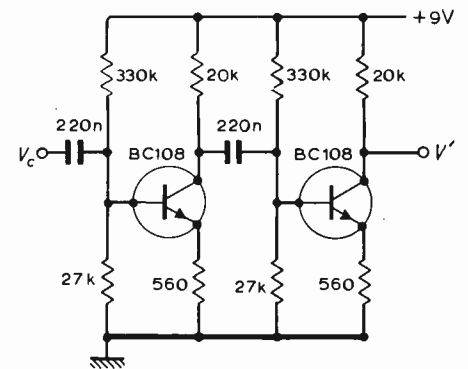

Fig. 14. Amplifier for control voltage fed to squelch circuit provides voltage gain of 56dB.

Recovery rate can be adjusted by varying the value of the resistor R'_3 in the driver circuit of Fig. 7. In those cases where attack is very fast it is advisable to employ a variable resistor for R'_3 . However, where the attack rate is retarded by a large-value resistor R'_4 then the same value could be used for R'_3 without need for a preset resistor.

A shunt volume compression system for audio signals would require a driver stage of the form shown in Fig. 7(a). However if the driver stage of Fig. 7(b) were used, the system would provide volume decompression. The system is not

as sensitive as that suggested for a.g.c. operation because the d.c. output level reaches only half the peak output voltage.

Automatic squelch circuits

An a.g.c. system containing a junction f.e.t. offers an attractive squelch possibility for audio amplifiers in communications receivers. In this application the f.e.t. is used as a switch. Reference to Fig. 2 shows that a change in V_{gs} of less than 0.5 volts will turn the device from an off to an on state. Thus by preceding the a.g.c. system with a stage of voltage amplification, fairly small signals can operate the squelch

circuit. The stage may be controlled either by received carrier or audio signal. The threshold level would be set just above the receiver noise level, so only the required audio signal would be amplified. The squelch would operate some several seconds after the cessation of carrier or audio signal. As the squelch circuit will be either on or off, the problem of l.f. instability, and consequent protective measures, does not apply.

Of course the squelch can be operated manually by supplying the required direct voltage at the f.e.t. gate. This would normally be effected when switching from the

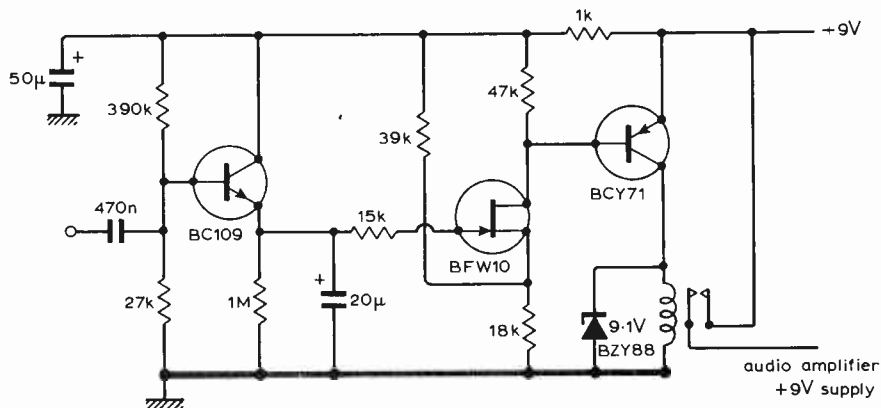

Fig. 15. Battery-saving circuit interrupts receiver supply 15 seconds after cessation of an audio signal, but switches on in a few milliseconds.

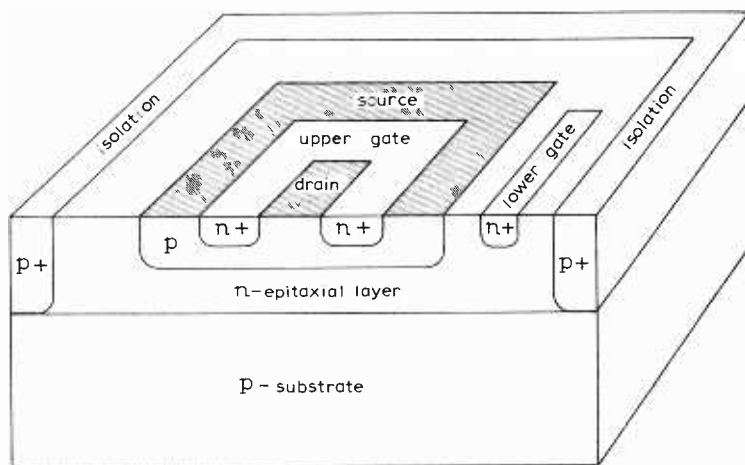

Fig. 16 Junction f.e.t.s could be integrated with conventional bipolar i.c.s, as the consequent degraded performance is probably acceptable for a.g.c. use.

receive mode to the transmission mode of operation of the transceiver.

A practical shunt circuit for a squelch facility is shown in Fig. 13. The circuit has been designed to provide squelch for an amplifier having an input impedance of $50k\Omega$, and a $-3dB$ frequency of $250Hz$. The output of the detector stage of the receiver is shown as the voltage source V_s in the diagram.

Pre-amplification of the control signal necessary for squelch operation may be attained using a circuit such as that of Fig. 14. This stage provides a voltage gain of about $56dB$, with quiescent current of less than $500\mu A$.

The control signal may be derived either from the carrier signal or the audio modulation in the receiver. In the case of a.m. receivers the control signal can be taken at the detector stage. The audio amplifier would then be 'un-squelched' by the d.c. output of the detector stage, due to carrier switch-on. As the squelch circuit is a.c. coupled, the squelch will operate about 15s after the cessation of audio signal.

In the case of f.m. receivers the squelch may be voice or carrier operated. For a voice-operated squelch the control signal can be taken from the detector output. However for carrier operation it is usual to monitor the d.c. output of a noise detector. For a noise output there is no carrier

present and the squelch is in operation. For zero noise output a carrier signal exists and consequently the audio amplifier is un-squelched. In this case the v.c.r. stage of the squelch circuit would be driven by a circuit of the type shown in Fig. 7(a) rather than by that shown in Fig. 7(b).

Battery saving circuit

As an audio amplifier can incur a considerable power drain in portable transceivers it is preferable that the power supply to the amplifier is interrupted during the absence of received signal. Thus a switch, controlled either by the presence of a carrier or audio signals in the receive mode of operation, would be very useful for battery economy. A practical circuit for such a switch is shown in Fig. 15. This circuit supplies an a.f. amplifier with a 9-V potential within a few milliseconds of receiving a carrier or audio signal in the transceiver. Fifteen seconds after the cessation of the signal the supply potential is interrupted.

The junction f.e.t. in integrated circuits

The planar construction of present-day junction f.e.t. would seem to render the device suitable for integration in monolithic circuits. However integration has been found difficult due to the high degree

of control required for impurity concentrations and dimensions of the device. For example, a small decrease in the channel resistivity can cause a large increase in the threshold voltage of the device*. Large values of the threshold voltage are clearly unsuitable for integrated circuit applications. Nevertheless these difficulties could disappear as integrated-circuit technology develops.

Of interest in the context of this article is the possibility of integrating a junction f.e.t. into monolithic audio amplifiers using bipolar transistors. It might be worthwhile to integrate a signal-amplitude control circuit on a separate monolithic chip.

Because the dimensional and resistivity requirements of the junction f.e.t. are different from those of n-p-n bipolar transistors a choice must be made between two options.

The first is a modified device fabrication process, in which the processes of epitaxy and diffusion are applied to arrive at the best compromise between bipolar and field-effect transistor performance. Being a deviation from the standard i.c. production processes this would result in a high cost per chip unless circuits of general applicability are considered. The process could be confined to production of signal amplitude control components suitable for most of the applications discussed.

The second option is the conventional bipolar fabrication process with an additional component having a degraded but f.e.t.-like performance. For applications like those discussed, where integration may be commercially viable, this second option may be useful. With this process the signal-amplitude control circuitry may be included in the audio amplifier monolithic circuits at very low cost.

As the f.e.t. is used at low frequencies for its well-controlled channel resistance property, a device having a degraded performance will quite likely be acceptable. An example of such a device is the p-channel depletion-mode junction f.e.t. shown schematically in Fig. 16. (For this particular device it would be necessary to reverse the polarities of the biasing circuitry shown earlier.)

*R. M. Berger and R. P. Donovan 'Fundamentals of silicon integrated device technology, Vol. 2' Prentice Hall 1968, pp.411-3.

About People

W. J. Bray, M.Sc. (Eng.), A.C.G.I., D.I.C., M.I.E.E., director of the Post Office's Research Department since 1966, has been appointed a visiting professor in the Department of Electronic and Electrical Engineering, University College, London. Educated at Imperial College, London University, he



W. J. Bray

joined the Post Office in 1934 as an assistant engineer. He led the U.K. team which developed the satellite earth station at Goonhilly, Cornwall, a design which has been used as the basis for satellite earth stations throughout the world. Mr Bray has also played a leading role in the Post Office's development of inter-city microwave communication systems. For his lectures at University College, Mr. Bray is taking as his theme the future of telecommunications and its increasingly important influence on society.

S. Neville Watson, O.B.E., F.I.E.E., chief engineer of B.B.C. Television, is the 1972/3 chairman of Council of the Royal Television Society. Mr Watson, who is 58, joined the B.B.C. in Newcastle in 1933 and transferred to London five years later. He was appointed head of the television transmission section of the Designs Department in 1948 and, in 1964, became head of the Designs Department. He has held his present position since 1968.

The 1971 I.E.E.E. Award in International Communication, which consists of a plaque and \$1000 presented by I.T.T., has been given to **Dr Eugene F. O'Neill** "for outstanding technical

innovations and management the development of many key technologies underlying the present day international communications art, especially Telstar, the first operational telecommunications satellite, as well as his earlier contributions to transoceanic cable telephony". Dr O'Neill, who is 54, is executive director of the Toll Transmission Division, Bell Laboratories, in Holmdel, New Jersey, where he is responsible for long-haul transmission development of guided signal systems on coaxial cables, submarine cables and millimeter waveguide, and radiated signal systems using microwave radio relay and satellites. Following graduation from Columbia University in 1941 he joined the technical staff at Bell Laboratories. In 1961, Dr O'Neill became director of satellite communications and served as Bell Laboratories' project manager for Telstar.

W. E. Thorneycroft, B.Sc., M.I.E.E., was recently appointed resident engineer at the B.B.C. Far Eastern Relay Station in succession to **J. P. Atkins**. Since 1964 Mr Thorneycroft has been engineer-in-charge of the Daventry transmitting station and among his earlier appointments were engineer-in-charge at Moorside Edge and at Rampisham.

G. B. Miller, B.Sc., F.I.E.R.E., has become managing director of Evershed and Vignoles Ltd., Chiswick, London, in addition to being deputy managing director of Avo Ltd. at Dover, and managing director of the Record Electrical Company Ltd. at Altrincham, and of Taylor Electrical Instruments Ltd. at Dover. All four companies are members of the Thorn Measurement Control and Automation Division, of which Mr. Miller is deputy managing director. The other companies in the Division are H. W. Sullivan and Thorn Automation Ltd. **E. Willis-Jones**, B.Sc.(Eng.), M.I.E.E., the former managing director of Evershed and Vignoles Ltd., continues as chairman of that company, and of the Thorn M.C.A. Division and all its member companies.

Richard King, aged 42, has been appointed director and general manager of Pye TVT Ltd.

manufacturers of television broadcast equipment. Mr King joined Pye in 1951 becoming southern area manager in 1960 and sales manager in 1964. At the time of the amalgamation of the radio and television companies Pye, Ekco, Ferranti and Invicta in 1966, he became sales director of Pye Group (Radio & Television) Ltd. He spent 1971 in Australia with a Pye associate company, Electronic Industries Ltd.

A new department has been formed within the Electro-Acoustics Division of Philips Electrical to look after the video cassette recorder and products from Philips Security Systems and three new appointments have been made. **Bob Livingstone**, previously product manager in charge of magnetic tape, has been appointed the commercial manager for video cassette recording, magnetic tape, and Philips Security Systems. **Colin Mitchell**, who has been involved with the v.c.r. since its introduction to this country, has become product manager for v.c.r. equipment. **Ian Marchant** has been appointed product manager for all magnetic tapes and cassettes as well as Philips Security Systems.

C. C. Farrow, the new chairman of council of the Telecommunication Engineering and Manufacturing Association, is a senior executive with Plessey Telecommunications. Previously vice-chairman of T.E.M.A. Mr Farrow succeeds **L. M. Price**, C.B.E., of G.E.C., the retiring chairman. Mr Farrow joined the telecommunications industry in 1923 and was export sales director with Automatic Telephone & Electric Company Ltd.

J. S. Whyte, M.Sc.(Eng.), F.I.E.E., director of the Operational Programming Department of Post Office Telecommunications has been appointed a vice-president of the Royal Institution. Mr Whyte joined the Post Office research station at Dollis Hill in 1939. Part of his early career with the Post Office was spent at the radio laboratories at Castleton, South Wales, where he led the team responsible for developing test equipment for microwave radio-relay links: one outcome of this work – the technique of white



J. S. Whyte

noise testing – was eventually standardized internationally for transmission system testing. Returning to Dollis Hill in 1957, he worked on a number of research projects, notably on pulse code modulation. After several years on loan to The Treasury in charge of Government computing, he returned to the Post Office in 1968 and was appointed deputy director of engineering.

C. G. Butler, M.I.E.E., of the B.B.C. Engineering Division, has relinquished his duties as superintendent engineer transmitters to enable him to devote his whole time to special duties as assistant to the director of engineering. Mr Butler joined the Corporation in 1940 after employment in the Post Office Engineering Department and the Air Ministry. Mr Butler is succeeded by **G. E. Turner** who joined the B.B.C. in 1938 at Daventry transmitting station. In 1942 he joined the then Station Design and Installation Department, leaving in 1957 to serve at the Droitwich station. In 1963, Mr Turner was appointed engineer-in-charge of the Woofferton External Services station.

The following officers of the Industrial Council for Educational and Training Technology, have been elected for the year 1972-1973. President: **Professor R. C. G. Williams**, O.B.E., Ph.D., F.I.E.E., F.I.E.R.E., chairman; **Captain R. L. Clode**, R.N. (Rtd), F.I.E.E., vice-chairmen; **H. A. Randall** and **F. Duerden**, B.Sc., M.I.E.E. Professor Williams was the founder chairman of ICETT (formed in 1966) and has now been elected as its first president. Captain Clode, who has been a member of council since its formation, is a divisional secretary of the Electronic Engineering Association. Mr Randall is managing director of ESL (Bristol) Ltd and Mr Duerden is a consultant in the Research Division of the Marconi Company.

OBITUARY

Edgar M. Lee, B.Sc., F.I.E.E., who, with the late C. R. Belling, formed Belling & Lee Ltd in 1922, died on 3rd June. Born in 1902, he graduated at King's College, London, in 1921 and did post-graduate research with the English Electric Company before forming Belling & Lee. He was managing director of Belling & Lee when it was taken over by the Philips organization a few years ago. He then became chairman and for the past 18 months had been founder president. Mr. Lee was a founder member in 1933 of what is now the Radio & Electronic Component Manufacturers' Federation of which he served as chairman and president for several years. He also represented Britain at meetings of the International Electrotechnical Commission.

World of Amateur Radio

I.A.R.U. Region 1 conference

The International Amateur Radio Union Region 1 conference at Scheveningen, Holland, brought together delegates from 29 national societies having a total membership of over 250,000, of whom 60,000 are licensed amateurs. Among the many recommendations were that the societies should begin immediately to prepare for a possible I.T.U. World Administrative Radio Conference around 1978-80 and should actively seek the support of their national administrations on proposals affecting the amateur service (with certain notable exceptions, such as the U.K.; the lack of such collaboration was apparent at the 1971 Space Communications Conference). Efforts are also to be made to strengthen the Intruder Watch to eliminate any possibility that non-amateur stations operating in exclusive amateur bands could claim they are doing so without causing "harmful interference" in the absence of official complaints. In view of the increasing concern at the insufficient immunity of so much electronics entertainment equipment to strong electromagnetic fields, the Region 1 Bureau is to set up a working group of experts in the field of television and broadcast interference. More 28 MHz beacons are envisaged with the R.S.G.B. charged with co-ordinating future planning. Important decisions on v.h.f. band-planning were made, with particular reference to talk-through repeaters.

V.H.F. repeater at Cambridge

As forecast last month, the first British 144 MHz f.m. talk-through repeater is being set up at Cambridge by the Pye Telecommunications amateur radio club, with the callsign GB3PI, under a 12-month M.P.T. licence. It will transmit on 145.75 MHz with a power output of 10 watts and peak deviation of ± 2.5 kHz. The repeater will accept signals on 145.15 MHz when activated by a half-second 1700 Hz (± 20 Hz) tone signal (to be changed later to 1750 Hz). Aerials will be

vertically polarized. Initially the station will be at the Pye Telecoms premises at Cambridge but the repeater is expected to be moved to a better site which will put it within reach of London stations.

The decision to adopt 600-kHz separation, with all frequencies above 145 MHz, follows the latest I.A.R.U. Region 1 recommendations; this should eliminate some of the problems, including interference with c.w. operation and zonal band-planning, of the 1.6 MHz spacing generally used in West Germany. The tremendous impact of repeater operation on West German 144 MHz operation is underlined in the current issue of *VHF Communications*. This lists over 60 repeaters and states: "One might assume that the main result would be that the two-metre band would be full of repeater stations with no room for other modes. The opposite is the case. Activity is now virtually limited to the input and output frequencies of the repeaters and around the s.s.b. frequency of 145.4 MHz. A.M. activity has virtually ceased to exist in Germany." Repeaters are also in use in Austria, Denmark, Finland and Sweden and what is thought to be the first amateur linear translator for a.m./s.s.b. may be working soon in Czechoslovakia.

Amateur TV news

The British Amateur TV Club has warned members that the expected reduction of the 70cm band to 432-440 MHz (plus 430-432 MHz subject to geographical and power limitations) will mean that care will be needed to ensure that all sidebands are within the allocations. This may require the use of a low-pass video filter or a vestigial sideband filter.

Recent changes to the amateur TV licence permit the use of the general call "CQ TV" on phone by those wishing to establish contact with another amateur TV station; allows sound to accompany visual images provided this relates to technical matters concerned with the sending and receiving of the visual images; allows contacts with amateurs holding sound-

only licences; and authorizes portable operation at short notice at previously agreed sites.

Bob Roberts, G6NR, deputy head of the Department of Electronics and Telecommunications of the Polytechnic of North London (formerly Northern Polytechnic) has become the new president of B.A.T.C. in succession to Ivan James, G5IJ. As previously announced, B.A.T.C. is holding its 1972 convention on September 16 (1030 to 1800) at I.B.A. (formerly I.T.A.) headquarters, 70 Brompton Road, S.W.3.

From Australia comes news that amateur TV pictures transmitted on 432 MHz by Winston Nickols, VK7EM, in Penguin, Tasmania, have been received by several amateurs in Melbourne, a distance of 240 miles.

To beam or not to beam

In recent years, the DX-seeking h.f. amateur has increasingly used or coveted the three-element Yagi or the two-element Quad beam aerial; while those without such facilities tend to fall back on the W3DZZ-type multi-band trap dipole, the G5RV multi-band aerial with 102 ft span or one of the space-saving verticals. But there are an extremely large number of other aerials which regularly tend to be discovered or rediscovered and which can provide effective operation on one or more bands. For example the end-fed long-wire aerial, particularly useful in its 132 ft version; the off-centre fed Windom and VS1AA aerials; the $\frac{5}{8}$ - λ vertical providing a useful degree of vertical directivity; the still effective, though increasingly rare "Zepp"; the various forms of driven beams including the W8JK bi-directional and the "ZL-special" unidirectional version in which the elements are fed 135° out of phase; and many, many others. Indeed one of the fascinations of h.f. operation is that with a little wire and buildings, masts or trees as supports one can quickly put up and try many different systems. Usually this immediately results in an increase in DX owing to the so-called "new-aerial effect" resulting from the added incentive to operate when trying out a new aerial.

Recently there has been a marked revival of interest in various forms of large loop aerials, of which the basic Quad element is one example. The mechanical problems of Quad construction have led to the development of "delta" (triangular) loops with mechanically simpler arrangements, and more recently the use of the one-wavelength triangular loop without reflector elements. Not all amateurs can put up large outdoor aerials; one hears quite a lot of stations using loft, roof-space or other indoor aerials. There is no doubt that a good deal of power gets lost in the hostile environment of water-tanks and electrical wiring but it is surprising how effectively such aerials can often prove. Recently, on the advice of Brian Booth, G3SYC, I have been trying a roof-space, single-section end-fed W8JK on 21 MHz, and find little difficulty in working a modest amount of DX.

Pat Hawker, G3VA

New Products

Low-frequency oscilloscope

A Telequipment dual-trace, solid-state, storage oscilloscope, type DM64, with a 10MHz bandwidth, has been introduced by Tektronix U.K. Storage-time capability is greater than one hour and the normal writing speed of 25cm/ms can be extended by a factor of 10 to 250cm/ms. An X-Y display facility is incorporated (bandwidth: d.c. to 1MHz, with the phase error less than 1° at 10kHz). The bandwidths of the vertical deflection systems are: d.c. to 10MHz, -3dB (a.c. coupled). Input impedance is $1\text{M}\Omega$, $+47\text{pF}$ (approximately); rise time 35ns; and voltage measuring accuracy, $\pm 5\%$. A variable control provides continuous variation between ranges and offers uncalibrated coverage up to 125V/div.

The magnifier in the horizontal amplifier operates over the full timebase range and increases the fastest sweep speed to approximately 20ns/div. Bandwidth is d.c. to 1MHz, -3dB . Sensitivities are 200mV/div or 1V/div. The 23 calibrated sweep speeds, in the horizontal deflection system, range from 100ns/div to 2s/div. Trigger modes: sources are internal from either channel, alternate, or external; slope is positive or negative; coupling is a.c. or d.c. The trigger level control selects any point on the leading edge of the input signal slope and a single-shot facility with lockout is provided.

The h.f. sync provides synchronization of the timebase from 1 to 10MHz; and the TV sync triggers at TV field or line rates.



The c.r.t. is a flat-faced bistable storage tube with beam deflection blanking and a viewing area of $8 \times 10\text{cm}$. The graticule is 8×10 divisions, each division measuring a nominal 1cm. Tektronix U.K. Ltd, Beaverton House, Harpenden, Herts.

WW319 for further details

Logic-controlled amplifier

The DLA-1 module consists of a unity-gain amplifier, which may be used in either the source-follower or inverter mode, the type of operation required being selected by external logic-level inputs to a switching circuit. Gain-equality in the two modes is within 5%, and adjustment for precise balance is provided. The input to the amplifier is taken to a zero-crossing detector, which produces at its output a t.t.l./d.t.l.-compatible level, indicating the polarity of the input. The sensitivity of both the polarity-sense amplifier and of the signal amplifier is increased by a common preamplifier, the gain of which can be adjusted externally from unity to 1000. The input of the unit will accept voltages in the range $\pm 5\text{V}$ into $100\text{k}\Omega$ minimum, the voltage offset referred to the input being a maximum of 5mV, trimmable to zero. The output range of the amplifier is $\pm 5\text{V}$. Power supplies of 15V, positive and negative, are required. The DLA-1 is a $2 \times 2 \times 1\text{in}$ epoxy-encapsulated unit, with pins for printed-board mounting. Davian (Instruments) Ltd, 52 Cardigan Street, Luton LU1 1RR.

WW320 for further details

Polycarbonate capacitors

A range of high stability polycarbonate capacitors, designated the TPA range, has been released by M.F.D. Capacitors. This range has the same performance specification as the original "A" and "R" ranges but sizes are substantially reduced. Each unit consists of a matched pair of non-inductive windings and the capacitors have tolerances from $\pm 5\%$ down to $\pm \frac{1}{2}\%$. Standard E6 capacitance values listed range from $0.01\mu\text{F}$ to $22\mu\text{F}$.

Insulation resistance is 50,000 ohm-farads, power factor less than 0.3%, and the operating temperature range -55 to $+85^\circ\text{C}$, although operation up to $+100^\circ\text{C}$ is permissible with a 20% voltage derating. Claimed stability is $\pm 0.2\%$. M.F.D. Capacitors Ltd, 10 Delucy Avenue, Alresford, Hants.

WW301 for further details

Portable resistance bridges

Three instruments comprise the Startronic, battery powered resistance bridge series. "Lohmeter" Model 100.2 has a double decade scale of 11in calibrated 0.5 to 50 , with five ranges from 0.05Ω to $50\text{k}\Omega$. A variation, Model 100.2 S/D, has a single 11in decade scale calibrated 0.5 to 5 , for a higher order of resolution. The five ranges are from 0.05Ω to $5\text{k}\Omega$. The second instrument in the series, "Milo-meter" Model 108.2, is a single range bridge for measuring very low resistances, and is calibrated 0 to $160\text{m}\Omega$ over an 11in scale. Its accuracy is $\pm 2\%$ $\pm 1\text{m}\Omega$. Measuring current is controlled via a six-position switch calibrated 50, 100, 200, 300, and 600mA, and a third terminal provides an inbuilt negative resistance of approximately $10\text{m}\Omega$, for balancing

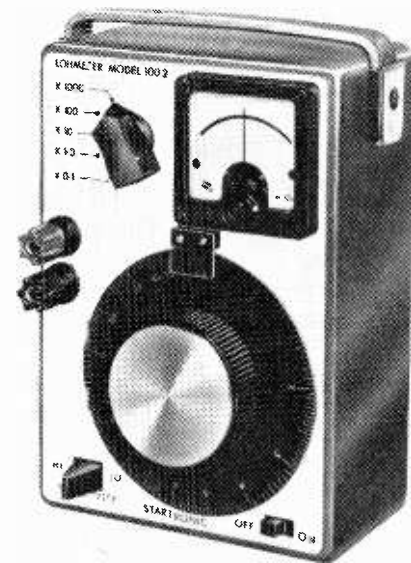

lead resistance. A comparison bridge, Model 110.2 (see accompanying photograph) completes the series. This instrument provides for direct comparison of resistance values from 5Ω to $10\text{k}\Omega$, with a continuously variable calibration of $\pm 10\%$. Accuracy is 0.1% between $\pm 5\%$, and 0.2% between $\pm 10\%$. A five-position selector switch enables an external standard or any one of four internal standard resistors to be selected. Startronic Ltd, Beeching Road North, Bexhill-on-Sea, Sussex.

WW322 for further details (Model 100.2)

WW323 for further details (Model 108.2)

WW324 for further details (Model 110.2)

Impulse peak voltmeter

A battery powered portable instrument for measuring peak voltage values obtained during impulse tests at high voltages, the type 669, manufactured by Robinson & Partners, will measure and hold either positive or negative impulse voltages for a period long enough to read and record. It accepts the standard $1/50\mu\text{s}$ impulse wave and also operates on wave fronts down to $0.2\mu\text{s}$. Measurement accuracy is $\pm 3\%$ for full waves. Deviation of stability over several weeks is of the order of $\pm 0.5\%$. The probe may be located near the voltage divider on the impulse generator and is

connected to the measuring instrument by a coaxial cable which may be up to 100ft in length without affecting the calibration. Provision is made for checking battery voltages and for static calibration (an external calibrator type No. 769 is available as an ancillary if required). A jack socket on the front of the instrument permits the use of an external voltmeter and/or digital readout meter, and an outlet socket at the rear of the instrument allows the use of an external reset facility. F. C. Robinson & Partners Ltd, Brighton House, High Street, Ewell, Epsom, Surrey.

WW328 for further details

Dual-in-line i.c. sockets

Contact between the i.c. legs and the pins connecting the series A23-2055 socket to a p.c.b. is effected by means of gold or tin-plated copper areas, which are deposited on the plastic body of the socket. The plated body is in the form of a saddle, over which the i.c. legs are slipped to make a complete surface rather than the conventional point contact. This results in the avoidance of any i.c. leg damage (since no insertion force is required to mount the i.c.). Sockets are available having dual-in-line or quad-in-line solder pins, which will accept standard 14- and 16-lead d.i.l. i.c.s. Prices start at $7\frac{1}{2}\text{p}$ each for large quantities, and a custom design service to any special requirement is offered. Jermyn Manufacturing Ltd, Vestry Estate, Sevenoaks, Kent.

WW304 for further details

Versatile measurement system

System 680R, which is built around an electrical test meter having eighty ranges on a scale length of 128mm, is produced by E B Marketing. The test meter has 13 d.c. voltage ranges from 0.1 to 2000V f.s.d., 11 a.c. voltage ranges from 2 to 2500V, 12 d.c. current ranges from $50\mu\text{A}$ to 50A and 10 a.c. current ranges from $250\mu\text{A}$ to 5A. Resistance may be measured up to $100\text{M}\Omega$ on six ranges including a low ohms range

Pulse generator

The Advance Model PG59 pulse generator comprises a clock generator followed by two channels giving independent control of delay, pulse width, rise and fall times, d.c. offset and amplitude. Outputs may be used separately, summed on to one line (still retaining full control of all parameters) or the output channels may be driven from the same pulse source. Frequency coverage is from 1Hz to 10MHz in decade ranges with intermediate calibrated control (20MHz in double pulse mode). Delay and width on each channel are selectable from 25ns to 1s in decade ranges. Output amplitude on direct output is variable from 3V to 10V

into 50Ω , and 20V into 50Ω , available with coincident drive on A + B sum mode. Normal output is variable from 1.5V to 5V into 50Ω (from a 50Ω source) and 10V maximum into 50Ω , with coincident drive on A + B sum mode. A switched attenuator on each channel allows 40dB in 10dB steps. Rise and fall times on each channel range are from (typically) 12ns to 1s (worst case 14ns). The PG59 weighs 27lb and measures $7 \times 17 \times 11\frac{1}{2}\text{in}$. Power requirements are 95-130V or 190-260V at 45-440Hz. Advance Electronics Ltd, Instrument Division, Raynham Road, Bishop's Stortford, Herts.

WW311 for further details

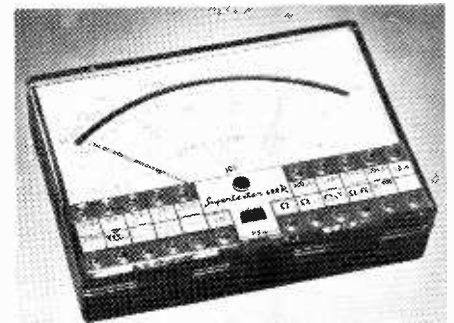

which will indicate $50\text{m}\Omega$. In addition, frequencies between one and 5000Hz and capacitance values up to $20,000\mu\text{F}$ may be measured. Sensitivity on the d.c. voltage ranges is $20,000\Omega/\text{V}$ and accuracy is 1%. Overload of one thousand times the f.s.d. is possible without damage to the meter movement. Accessories are available which convert the basic meter into a light meter reading two to two hundred lux, an instantaneous electrical thermometer reading -50 to $+200$ degrees Celcius, a gauss meter and a phase sequence indicator. The basic meter is shown in the accompanying photograph. E B Marketing, 49-53 Pancras Road, London NW1 2QB.

WW325 for further details

Cermet trimmer

The Panton type 475 Certrim potentiometers from GDS Sales are available with resistance elements up to $1\text{M}\Omega$. Standard stock ohmic values for the type 475 are

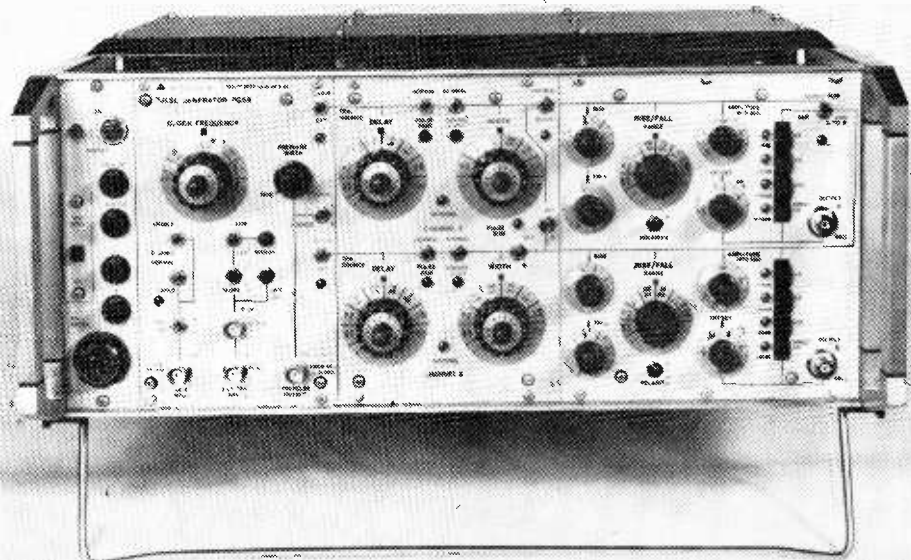
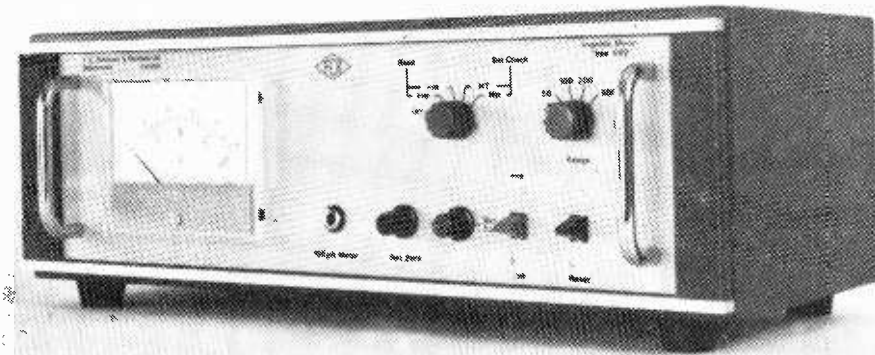

100, 200 and 500Ω and their decades up to 1MΩ. Tolerance is 10% and power rating is 0.75W at 70°C, derating to zero at 125°C. These 22-turn trimmers exhibit a temperature coefficient of 200 p.p.m./°C maximum, and measure 31.95 × 7.60 × 8.33mm. Connections are by standard printed circuit pins. GDS (Sales) Ltd, Michaelmas House, Salt Hill, Bath Road, Slough, Bucks.

WW318 for further details

Connectors for metric wire sizes

A range of wire connectors for use with metric wire sizes has been introduced by Thomas & Betts. The "Sta-Kon" range includes both self-insulated and non-insulated connectors in a variety of types. All the connectors are marked with the appropriate wire sizes, which range from 0.25 sq.mm to 300 sq.mm. A range of

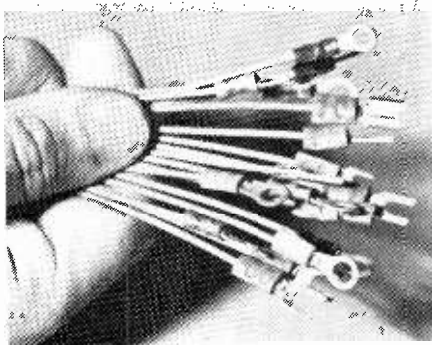

tooling is also available as part of the new system, which provides facilities for handling the connectors. Thomas & Betts Ltd, Greenhill House, 90-93 Cowcross Lane, London EC1M 6JR.

WW309 for further details

Tantalum capacitors

A series of resin-dipped, solid, tantalum capacitors for professional applications — coded TAP — has been introduced by ITT Components Group Europe. They have been designed for applications where a 21-day humidity rating will suffice, as against the 56-day rating given by existing metal-cased professional-grade tantalum capacitors. Capacitance values are available in the range 0.1μF to 680μF at tolerances of ±20% or ±10%. Rated d.c. voltages are 3, 6.3, 10, 16, 25, 35 and 50V and the operating temperature range is -55 to +85°C. The minimum leakage current after 3min at 20°C is 0.02C_NV_R(μA) where C_N is the nominal capacitance and V_R is the rated voltage. Having a printed coding, they are fitted with 0.5mm radial tinned nickel lead wires with a 5mm spacing for direct printed circuit mounting. ITT Components Group Europe, Capacitor Product Division, Brixham Road, Paignton, Devon.

WW305 for further details

Microwave signal source

Type 6070 solid state signal generator, manufactured by Marconi Instruments, is tunable over the frequency range 400 to 1200MHz. It is operated either from the front panel control or externally, and the attenuation range for either mode is at least 25dB (typically greater than 35dB). A low-pass filter in the output line ensures all harmonics are 20dB down on the fundamental. The r.f. signal can be square wave amplitude modulated from an internal source at a nominal frequency of

1kHz. An output of 0 to 15V d.c., directly proportional to the oscillator frequency, is available from a rear-panel socket. This can be applied to the traverse input of an X-Y recorder for broad band performance measurements on a swept basis. The unit contains a voltage regulated power supply and is suitable for operation from mains supplies in the 230 or 110V ranges. Marconi Instruments Ltd, Sanders Division, P.O. Box No.10, Gunnels Wood Road, Stevenage, Hertfordshire.

WW302 for further details



Dual-trace storage oscilloscope

The Philips PM3251 has a 50MHz bandwidth at 2mV/div input sensitivity, and 200μV/div at 5MHz and employs a "half-tone" storage tube with a variable persistence from under 0.3s to over 15min. With storage time, the instrument has been designed so that trace brightness is at a minimum when storage time is a maximum. Storage time is variable from 2 hours at a minimum brightness to 15 minutes at maximum brightness. Operation of the PM 3251 can be in any of three

modes: normal, variable, persistence and store. In the first mode the instrument operates as a normal dual-trace oscilloscope. In the variable-persistence mode, the waveform is fed both into the storage mesh and straight on to the normal screen, the persistence time being determined by the persistence setting. In the third mode, single-shot and other waveforms can be stored. Pye Unicam Ltd, York Street, Cambridge.

WW307 for further details

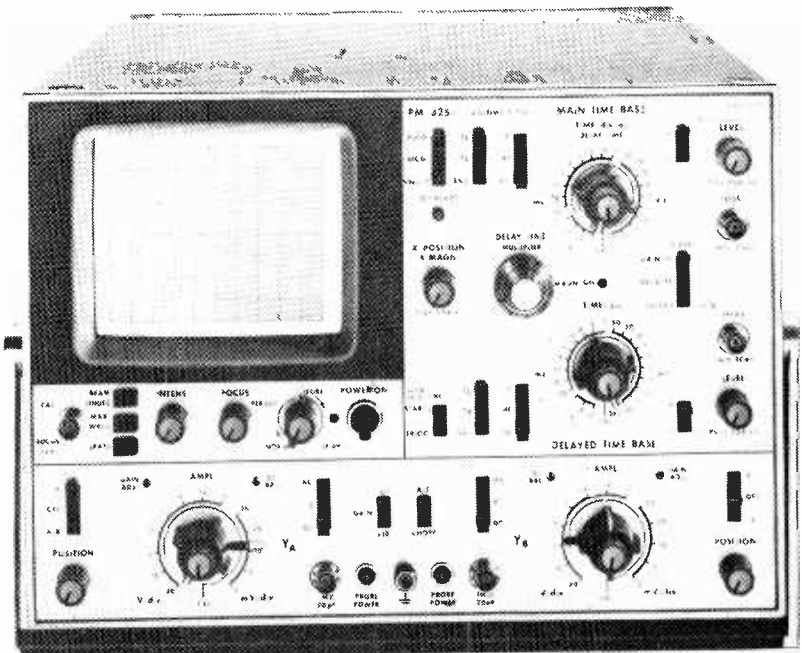

Shrouded transformers

A range of transformers and chokes has been introduced by Gresham Transformers. The range, designated type 520, has been produced for manufacturers of amplifiers, control systems and similar equipment. Ratings vary between 7 and 300W in 12 sizes. The 520 range can be half shrouded or fully shrouded and provides three mounting positions with a variety of terminations. A large number of individual variants of the range are available by choosing combinations of fixings, terminations, primary and secondary voltages, electrostatic screens, etc. Gresham Transformers Ltd, Hanworth Trading Estate, Feltham, Middx.

WW315 for further details

Electronic wrist watch components

A three-piece set of matched electronic wrist watch components has been introduced by Motorola. The set comprises (1) a silicon-gate c.m.o.s., m.s.i. oscillator, divider and buffer circuit (2) a quartz crystal and (3) a miniature stepper motor. All that is additionally required to construct a watch are a trimmer capacitor, a miniature battery, a watch case, dial and hands and gearing to couple the motor to the hands and to a day and date display.

The oscillator, divider and buffer are housed in a 6-lead ceramic package type MC6160. Oscillator final output frequency is 0.5Hz (basic frequency 32kHz). Two parallel trains of pulses are produced, each at a frequency of 0.5Hz, and 180° out of phase with each other. The MC6160 draws 4.5μA from a 1.3V mercuric oxide battery and 5.0μA from a 1.5V silver-oxide battery. The type MTQ21 quartz crystal (NT-cut) is housed in a package measuring 18.8 × 3.3 × 4.19mm and has a frequency drift of less than 2 p.p.m. after repeated 0.4ms shocks of 1000g while the crystal can withstand a 3000g shock, without damage. Tolerances and drifts, output impedance and the input and output capacitances can be adjusted out with an external trimmer capacitor. The series MTM stepper motor rotates 180° for each one second input pulse from the c.m.o.s.

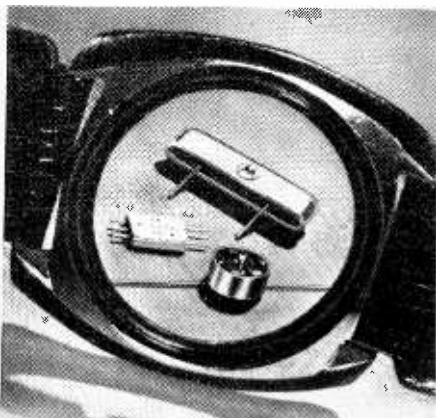

divider. Drive voltage range is from 0.8 to 1.8V and average current consumption 8.5μA at 1.3V and 10μA at 1.5V. The motor measures 2.70 × 6.35mm.

Overall performance of the system includes an expected time error of 0.6 sec/day with temperature excursions of ±10° maintained for 24 hours. The long term ageing rate of the crystal represents an approximate error of 0.08s per day. The recommended batteries (each measuring 5.6mm high × 11.6mm diameter) will last for longer than a year. Motorola Semiconductors Ltd, York House, Empire Way, Wembley, Middx.

WW312 for further details

Interaction oscillators

A range of extended interaction oscillators, designated the VKE-2401A series, has been introduced by EMI-Varian Ltd, for use in plasma studies and experimental applications where high power at millimetre frequencies is required. Each tube delivers a typical output of 35W into a matched load at a frequency selected between 50 and 80GHz. Outputs up to 50W are attainable in the 50 to 60GHz



range. They are water cooled and constructed for a lifetime of approximately 5,000 hours. Typical operating conditions are: frequency, 60GHz; power output, matched load, 35W; power output, optimum load, 50W; electronic tuning range, 150MHz; beam voltage, 6.8kV d.c.; beam current, 112mA d.c.; weight, 10.25lb. EMI-Varian Ltd, Hayes, Middx.

WW321 for further details

Portable TV camera

The Grundig "Super Compact" FA75 series TV camera is battery operated and has a single 8mm diameter cable connecting the camera and video output to the battery pack. The vidicon tube is of the 16mm miniature type. Two models are available,

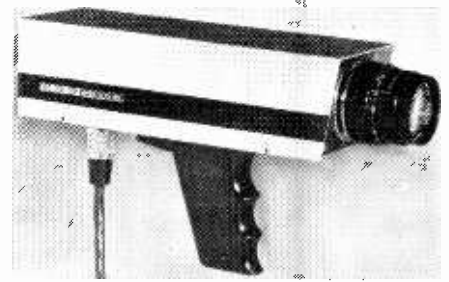

types FA75 and FAE75, the latter incorporating an electronic viewfinder giving a picture 36 × 48mm. Main specifications: output is a positive composite 1V pk-to-pk into 75Ω, crystal controlled line drive, 625 lines, 50 scans, 2:1 interlace ratio; resolution of 210,000 picture elements; power supply is 6V d.c. +5% -10%, Ni-Cd battery pack with shoulder strap, capacity 2½ hours operating time with viewfinder (7W), charging time 14 hours; dimensions with viewfinder 215 × 130 × 67mm, weight 2kg; battery pack is 148 × 105 × 39mm, weight 1kg. J. O. Grant and Taylor (London) Ltd, Arlingham House, South Mimms, Potters Bar, Herts.

WW326 for further details

Miniature potentiometer

The Ohmic model M12L hot moulded miniature potentiometer has a shaft lock bushing. It is an industrial grade unit available with either linear clockwise or counter clockwise taper and in three standard shaft lengths — 12.5, 16, and 22mm — with either a plain round shaft or screw-driver slot.

| | |
|------------------------|--------------------|
| Resolution: | infinite |
| Resistance range: | 100Ω to 1MΩ |
| Resistance tolerances: | ±20%, ±10% |
| Power ratings: | ¾W at +40°C linear |
| | ¼W at +40°C log |

Ohmic are represented in the U.K. by Bourns (Trimpot) Ltd, Hodford House, 17/27 High Street, Hounslow, Middlesex.

WW310 for further details

F.M. tape adaptor

The type D.C.F. 101 tape adaptor, manufactured by Lan-Electronics, enables analogue data, within the frequency range d.c. - 180Hz (3dB point) to be recorded on domestic tape recorders. Single or two channel versions are available. Main specifications are: mains input 110/240V, a.c., 50-60Hz, consumption 3W; input signal level ±1V to ±5V for ±40% deviation (set as required); input impedance 22kΩ; f.m. output signal 5V pk-to-pk square wave from a 1kΩ source; recording overload indicator activated when deviation exceeds ±50%; noise level (carrier break-through) — 55dB. Lan-Electronics Ltd, 95 Farnham Road, Slough, Bucks.

WW316 for further details

Literature Received

For further information on any item include the WW number on the reader reply card

ACTIVE DEVICES

Data sheets specifying a series of r.f. power transistors from Ferranti Ltd, Electronics Department, Gem Mill, Chadderton, Oldham, Lancs, describe the following:

- 2N4040 — up to 8W at 400MHz WW401
- 2N4128 — up to 24W at 175MHz WW402
- 2N4430 — up to 5W at 1GHz WW403

We have received a leaflet listing the products of the companies (including Crystalonics, Unitrode and Electromech) represented by G. E. Electronics (London) Ltd, Eardley House, 182/4 Campden Hill Road, Kensington, London W8 7AS WW404

The "RCA Power Hybrid Circuits Product Guide" publication PHC-600, includes abbreviated data on linear amplifiers, voltage regulators and Darlington circuits WW405

Five of a series of data books, which index the basic parameters of solid state and microwave tube devices in an easily accessible form, have been sent to us by Technical Indexes Ltd, Electronic Engineering Index, Index House, Ascot, Berks SL5 7EU. Annual subscription covers two editions per year.

- Diode and S.C.R. sub. £13.80
- Linear Integrated Circuits sub. £12.00
- Digital Integrated Circuits sub. £16.10
- Transistor sub. £14.95
- Microwave Tube sub. £11.05

The services offered by Coutant Electronics Ltd, 3 Trafford Road, Reading RG1 8JR, for the custom design of thick film hybrid microcircuits are described in a leaflet WW406

We have received three product specification sheets from Measurement Technology Ltd, 26-30 John Street, Luton, Beds, LU1 2JE.

- Multiple safety barriers MTL 300 WW407
- Shunt diode safety barriers, MTL 100 ... WW408
- Thermocouple temperature transmitter, MTL 400 WW409

PASSIVE DEVICES

Catalogue No. 209 contains details of the complete range (over 1500) of components from A. F. Bulgin & Co. Ltd, Bye-Pass Road, Barking, Essex WW410

Prices of connectors, cables and switches are contained in a leaflet we have received from Future Film Developments, 90 Wardour Street, London W1V 3LE WW411

AEI Communications Corporation, P.O. Box 507, M/S 1123/TA, Lansdale, Pa. 19446, have sent us data and prices of test accessories including return loss bridges, r.f. detectors and cross modulation filter WW412

Two types of 0.025in square wire-wrapping male pins and connecting components (described as "disconnect. #") are described in Bulletin 105, Berg Electron NV, Helftheuvelweg 1, P.O. Box 2060 's-Hertog, enbosch, Holland WW413

We have received a catalogue describing a new coaxial cable with an outer conductor of seamless tubing — the "Coaxitube". Seaelectro Ltd, Walton Road, Farlington, Portsmouth, Hants WW414

A catalogue and price list for Amphenol connectors includes details of the MS and 62GB shell types, series 221 miniature strip types and the 133/143 series for p.c.bs. Intel Connectors Ltd, Henlow Trading Estate, Henlow, Beds WW415

COMMUNICATIONS

We have received leaflets specifying the MLV series of solid state mobile TV relay links (MLV12010/7010/6010/2010). Microwave Associates Ltd, Cradock Road, Luton, Beds WW434

A range of aeriels from l.f. to microwave are described in a product leaflet from C & S Antennas Ltd, Knight Road, Strood, Rochester, Kent WW435

A description is given in a set of leaflets of standard aeriels (and special design availability) for mobile and hand held communication sets — v.h.f. and u.h.f. Panorama Radio Co. Ltd, 73 Wadham Road, London SW15 2LS WW436

Receivers (l.f. to s. h. f.), telemetry and test equipment are among products briefly described in a booklet. Astro Communication Laboratory (U.K.), Tower Street, Coventry, CV1 1JP WW437

Filters, duplexers and multicouplers from Airtech Ltd, Haddenham, Aylesbury, Buckinghamshire are specified in a catalogue we have received ... WW438

A set of product sheets available from Hatfield Instruments Ltd, Burrington Way, Plymouth, PL5 3LZ includes test sets, aerial matching units, attenuators, radio frequency bridges and decade boxes. A price list is included WW439

APPLICATIONS

High energy tapes and microphone characteristics are the subjects of two articles in Fact Sheet No. 3 from Studio 99 Video Ltd, 81 Fairfax Road, Swiss Cottage, London NW6 4DY WW416

EQUIPMENT

"Specipro" is a booklet describing service and production tools and equipment distributed by Special Products Distributors Ltd, 81 Piccadilly, London W1V 0HL WW417

We have received a book (1972 edition) covering the range of equipment and services from Hewlett Packard Ltd, 224 Bath Road, Slough, Bucks WW418 Technical data and prices of industrial, digital transducers are the subjects of a publication from

Orbit Controls Ltd, Alstone Lane, Industrial Estate, Cheltenham, Glos. GL51 8JW WW419

Specifications are given in a leaflet for the LB series of electronic timers (0.02s — 5m in eight ranges). Tempatron Ltd, 5 Loverock Road, Reading, Berks WW420

Data generator Model 216 (word length up to 16 bits) is described in a data sheet. Grange Electronics (Production) Ltd, Stone Lane, Wimborne, Dorset, BH21 1NF WW421

Microwave, i.f. and r.f. components are the subjects of product catalogue M81. Merrimac Research and Development Inc, 41 Fairfield Place, West Caldwell, NJ. 07006 WW422

Digital voltmeters SM210, SM211 and SM212 are specified in a data sheet we have received. SE Laboratories (Engineering) Ltd, North Feltham Trading Estate, Feltham, Middx WW423

Small electric ovens with automatic temperature control for curing, drying and stoving are the subject of publication LW/1271. Barlow-Whitney Ltd, Watling Street, Bletchley, Bucks WW424

Brief specifications for digital multimeters Digitest 750 and 501 are given in a product leaflet received from Dynamco, 91 Beddington Lane, Croydon, Surrey CR9 4PB WW425

The Model 5000, a combined digital multimeter and counter, is specified in a leaflet we have received. Lyons Instruments Ltd, Hoddesdon, Herts . WW426

Two publications sent to us by Tektronix U.K. Ltd, Beaverton House, Harpenden, Herts are: "Tekscope" Vol. 4, No. 3 WW427
Data on the series TM500 plug-in and measurement system WW428

Digital multimeters and a.c. power sources produced by California Instruments Company, 5150 Convoy Street, San Diego, California 92111, are described in a product sheet WW429

GENERAL INFORMATION

Three leaflets on books published by The Butterworth Group, 88 Kingsway, London WC2B 6AB, cover the subjects of radio, television and postgraduate electronics WW430

"EMI in Underwater Technology" is the title of a publication from EMI Electronics and Industrial Operations, Blyth Road, Hayes, Middx WW431

We have received a leaflet outlining a service, the "Pye Linkplan", to applicants for local commercial radio licences, consultants and programme contractors. Commercial Radio Manager, Pye of Cambridge Ltd, St. Andrew's Road, Cambridge WW432

The May 1972 edition of "Marconi Instrumentation" includes articles on measurement of non-linear distortion of the video signal and a low noise signal generator for the new u.h.f. mobile bands .. WW433

Real and Imaginary

by "Vector"

“... through a glass, darkly ...”

I think it was Jerome K. Jerome who said that it was impossible to enjoy idling unless one had plenty of work to do. Like when the project you're working on comes to pieces in your hands and is miles behind schedule and the Group Chief is making savage barking noises at your cell door. Under such conditions one of the best ways I know of wasting half-an-hour of the firm's time — and I pass this on in full awareness that I shall not get the Queen's Award for Industry for it — is to speculate upon what electronics will be like in A.D. 2000.

Somehow, A.D. 2000 has a remote ring about it. "So what?" is the thought that springs to mind. "I shall be too busy supporting daisies to bother." If that's your attitude, permit me to point out that the baby born today will be only twenty-seven years old when the tape-recorded joybells ring out.

One tip before you start, though (if I may presume). Don't be too influenced by Mr. Spock and his colleagues of "Star-Trek". They're much farther ahead in time and they've got some pretty far-out hardware, including the one which disintegrates a human body into its constituent atoms and then reassembles it on some far distant shore at the speed of light (very handy for dodging the queue on the Exeter by-pass). But they still seem to be stuck with vintage 1960 radar and TV screens; their radio still on occasions emits 1930-ish squawks and they're still stuck with control knobs and push-buttons. Not a thought-operated device in sight . . . but let him that is without sin cast the first stone. I've already fallen into the trap by mentioning tape recording which may well be in the museum by A.D. 2000.

There are snags in this crystal-gazing business, I find. At a superficial level it seems straightforward enough. Old Moore Vector can predict l.s.i. circuits that will make our present ones look like St. Paul's cathedral by comparison; he can visualize fully automated airways and driverless road vehicles belting along in safety at incredible speeds, monitored by electronic devices through all sorts of weather. Genuine 3-D colour TV (holographic?) with storage facilities is a "must"; probably the ultimate status symbol will be a viewing room in which illusions are presented from the four walls, floor and ceiling to immerse the viewer in the scene.

The input signals may be piped into the house or they may originate from a space station covering the entire country, or even half the globe.

The computer will be ubiquitous; not only in factories and offices but also in the home, where every detail of domestic life — well, almost every detail — will be organized by the machines, which by 2000 may have developed perilously close to the capability of original thought. The postal services as we know them will probably have disappeared in favour of facsimile and data transmission into the home.

I could go on *ad infinitum* but you can just as easily make your own blueprint for the future. Where we're likely to come seriously unstuck is that we can take no account of two factors, each of which can throw hefty spanners into our prognosticative machinery. These are, respectively, serendipity and possible changes in social structure.

Serendipity, the act of making discoveries unexpectedly and by accident, had had a greater influence on the development of electronics than professional self-esteem would have us admit. And when it happens it naturally disrupts the trend more than somewhat. For instance, in 1872, progress in communications was entirely in terms of signals transmitted via wire conductors. In that year a forecast of likely developments by the turn of the century might have included a trans-world telegraphic linkage by cable, possibly the electric telephone and — if you were a way-out prophet — even television over land-line (which didn't in fact materialize but a lot of people were trying). But in 1872 it would have taken a super-seer to declare that in 1901 signals would be sent across the Atlantic by means of electromagnetic waves. Nobody in 1872 could foresee that Hertz was going to upset the technological applecart; although this wasn't serendipity, some of the discoveries that made wireless telegraphy into a practical system undoubtedly were.

Neither can we allow for radical changes in social structure. Taking a worst case, it is even now within our power to bring a nuclear Flood of world proportions upon ourselves. If that happens and the only survivors belong to a primitive race, all our crystal-ball gazing

would become a nonsense. Electronics would vanish.

Or, as a less extreme example, there may be profound changes in outlook. Ever since history began, technology has developed via the profit motive; invention has centred in areas where there has been money to be made from it. In the Industrial Revolution the workers had a grim time of it;* living conditions were appalling and education was a prerogative of the rich. Great strides have been made since then and one of them is in the proliferation of universities and technical colleges, to enter which the password is intelligence, not the possession of this world's goods. But education is not the mere acquisition of knowledge; its most important function is to train the brain to enquire and to question.

Is it surprising then that the student population is beginning to bite the hand that feeds it? Is it surprising that a militant minority is becoming increasingly disenchanted at the prospect of a lifetime spent in the industrial or commercial rat-race and is intolerant of the established order? It's an ostrich attitude to pretend that all drop-outs are bone-idle unwashed layabouts; no doubt the movement has its quota but the great majority are highly intelligent youngsters who don't like the shape of things as they are and are saying so. It is they who will be the influential citizens of ten or fifteen years' time and while youthful intolerance may have mellowed somewhat by then, it is their views, whatever they may be, that will determine the pattern of the future, for the student revolt is a world movement.

What has this got to do with electronics? Everything. For electronics is a Vicar of Bray industry which follows dutifully in the wake of events. At present much of it is devoted to trivia and all of it to the almighty dollar — for example, presently existing techniques could be developed to make our roads much safer, but they would add perhaps £30 to the cost of a car, so nobody bothers overmuch. Safety devices have to be the subject of legislation before they are generally adopted. A change of outlook for the better would change the whole direction of electronics accordingly.

If, on the other hand, the change is in the direction of Orwell's "1984", then electronics will become the servant of the police state. The character of broadcasting could change overnight from a benevolent institution to an instrument for brainwashing. Even in the present state of our art, private conversations can be listened to across the street without the need for a bugging device in the room; telephone conversations can be tapped with ease; computer stores can be "milked" from a mile or so away — and at the moment we're not even trying awfully hard!

Perhaps after all we'd better give crystal-ball gazing a miss and get back to the job in hand before the Group Chief goes completely berserk.

*There is disagreement among historians on this point. Controversy is centred on both the material standard of living and the quality of life. — Ed.